

Fleck 7000 Greensand Installation & Start-Up Guide

Thank you for purchasing a Clean Water System! With proper installation and a little routine maintenance your system will be providing filtered water for many years.

Your new system comes with a printed Fleck Service manual, which along with this start-up guide will help guide you in the installation and start-up of your new system. The Fleck service manual covers other types of systems as well such as water softeners and filters, so there may be information in your Fleck service manual that does not pertain to your system. Please review this start-up guide entirely before beginning to install your system and follow the steps outlined for best results.



2806-C Soquel Ave Santa Cruz CA 95062

For assistance call: 1-831-462-8500

Email us: office@cleanwaterstore.com

More information online: www.cleanwaterstore.com

Pre-Installation

1. Review your packing list and make sure you have received all the parts before beginning installation.
2. If you are going to be turning off the water to the house and you have an electric water heater, shut off the power to the water heater before beginning installation in case water heater is accidentally drained.
3. Pick a suitable location for your filter system on a dry level spot where it won't be exposed to freezing temperatures. A minimum of 20 PSI is required. Maximum pressure is 90 PSI.
4. Get all of your plumbing parts together before beginning installation. Installation typically takes 3 to 5 hours. However after installation the Greensand Filter must be allowed to run through a complete backwash and rinse cycle (also called 'regeneration'). You don't have to be present for this first backwash necessarily, but it does take 90 minutes.
5. After the system is installed and running, your water may be discolored, or full of sediment or rust, particularly if this is older piping that has been exposed to iron or manganese for some time. Typically this clears up over a day or two, but can persist for weeks if the pipe is old galvanized iron pipe that is corroded.

Best Practices for Piping & Drain Installation

1. See typical installation (see Fig 1). The greensand filter is installed after the pressure tank.
2. Make sure to connect the inlet pipe to the Fleck 7000 inlet and the outlet to the outlet (see Fig 2). As you face the Fleck 7000 control from the front, the water enters on the right and exits on the left. From the back (see Fig 2) the water enters on the left. The inlet and outlet are attached to the bypass valve which is marked with arrows as well.
3. Make sure there is a working gate or ball valve before the Fleck 7000 Greensand filter and also one after as shown in the diagram. The pressure gauges are optional and not necessary but a hose bib (which is a faucet that you can attach a garden hose to) is strongly recommended after the Greensand Filter before the second ball valve. This makes it easy to rinse your new iron filter on start-up and gives you a place to test the water before it enters your household plumbing.
4. If you will be using copper piping, do not sweat the copper pipe directly on to the Fleck 7000 control valve. Avoid heating up the Fleck 7000 control valve plastic with the torch.

- You do not need unions to install your Fleck 7000 control. If you need to remove it, the Fleck 7000 has quick-release couplings that make it easy to put the Greensand Filter on by-pass and remove the filter system from the piping.
- The drain line tubing (not supplied) is connected to a drain from the drain outlet using flexible ½" ID tubing. Note that the drain can run up above the Fleck 7000 control and into a drain, it does not have to drain down, as the filter backwashes under line pressure from your well pump. Most plumbing codes require an air-gap connection, so that if your sewer or septic tank backs up, it cannot cross connect with the drain tubing.

Fig 1 - Typical Greensand Fleck 7000 piping installation with ball valve and hose bib after the filter

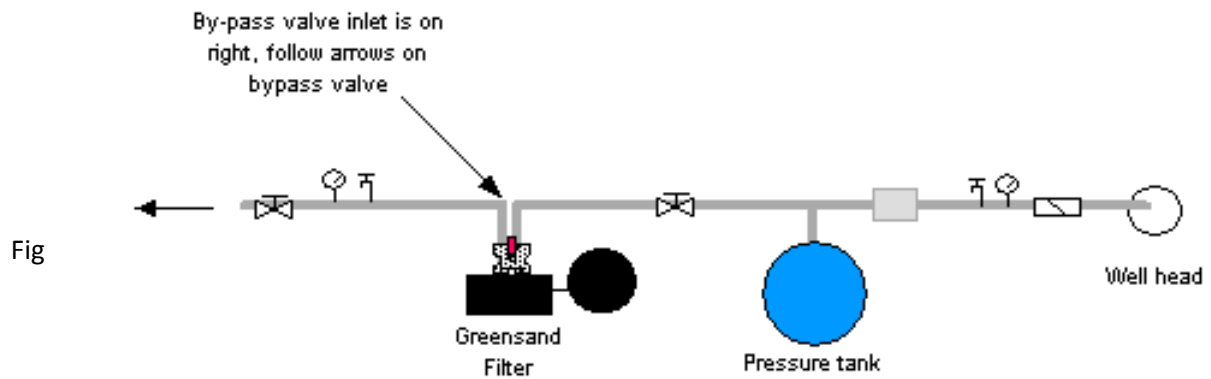
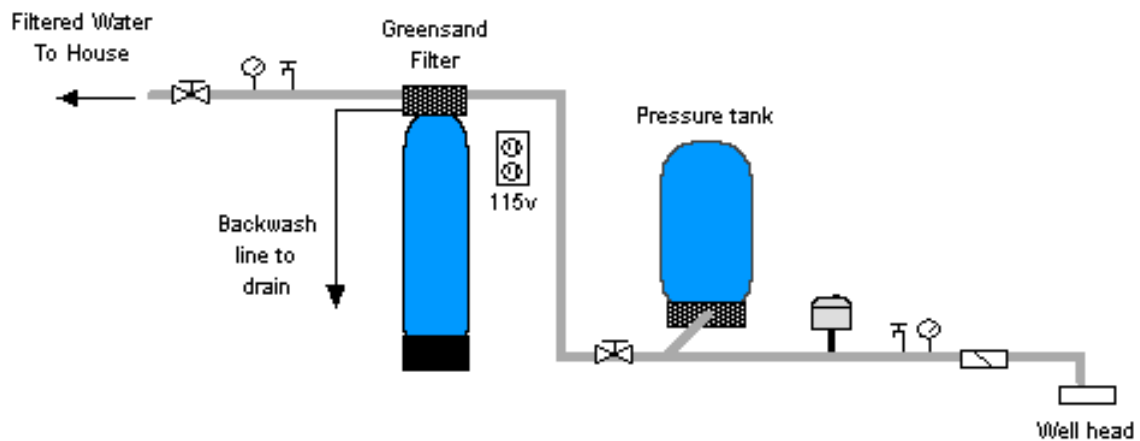

Fig

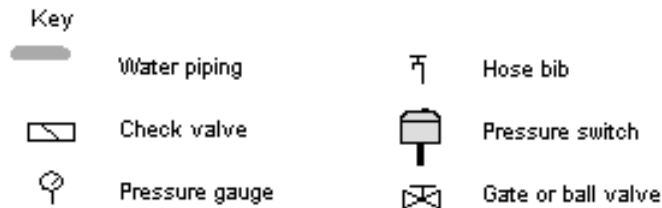

Fig 2: Fleck 7000 from the rear showing the inlet and outlet end-connector fittings 1" or 1-1/4" NPT in Noryl plastic. Brass end-connectors are also available for connecting to copper tubing.



Fig 3 Fleck 7000 side view

Fleck 7000 Greensand Control Valve



Installation Instructions

1. Unscrew by hand the entire Fleck 7000 control valve from top of tank if it was shipped screwed on. Place distributor tube in tank if not already inside tank. If not already done, make sure blue cap is on top of distributor tube, or wrap the top of distributor tube with electrical or duct tape. The idea is we do not want gravel or media to go down the distributor tube when you are adding media.

Fig 4 Greensand diagram showing cut-away of media and permanganate tank

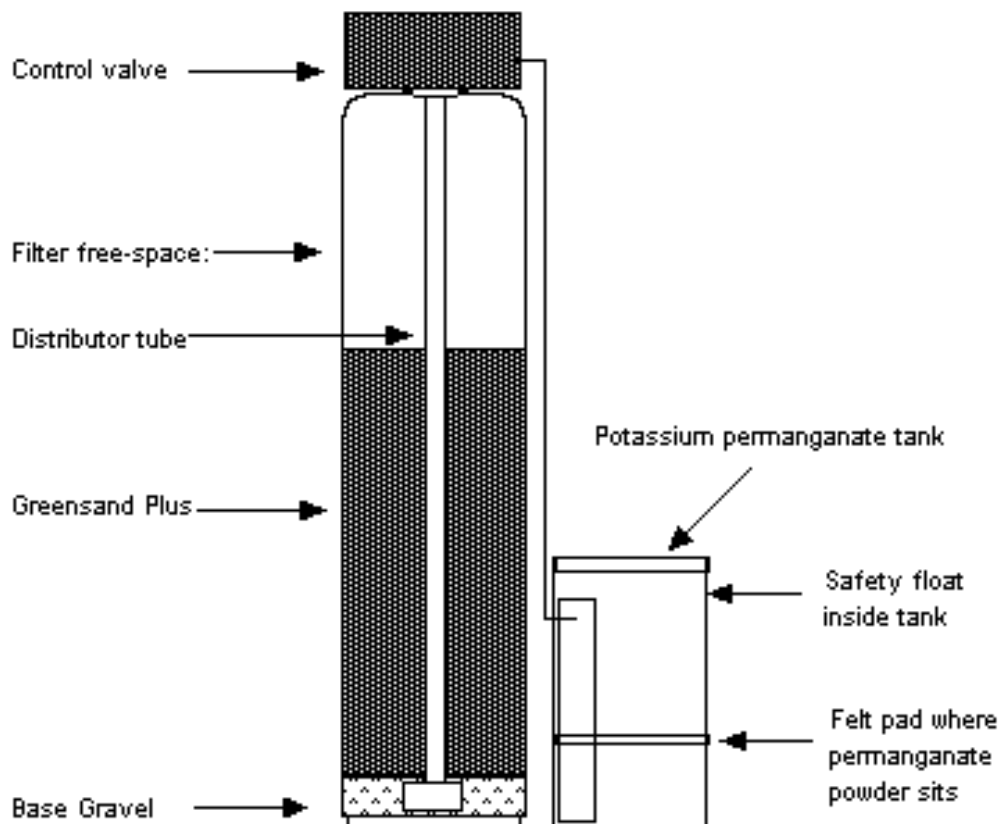

2. Add filter gravel supplied first, using the funnel sent with the greensand filter.
3. Next add greensand media. Tank will be approximately 2/3 to the 3/4 full.

4. Remove cap or tape from top of distributor tube. Be careful not to pull up distributor tube when removing cap or tape.
5. If possible at this point, fill tank completely with water. This will allow the greensand media to settle and eliminate the need of “purging” the air out of the tank later.
6. Add a small amount of vegetable cooking oil to the tank threads and screw on Fleck 7000 control valve carefully. Alternatively you can use silicone grease, but do not use pipe-joint compound, Teflon tape, or Vaseline or other petroleum greases to lubricate tank threads.
7. See how the Fleck by-pass is connected. Note that Items 2 in Fig 5 below are the pipe connectors and the other end is what gets attached to the control valve. Items 3 are the red clips that hold the pipe connectors to the by-pass valve. Your Fleck 7000 is usually shipped in the by-pass position.

Fig 5 Fleck 7000 bypass (shown in Service position, not the Bypass position)

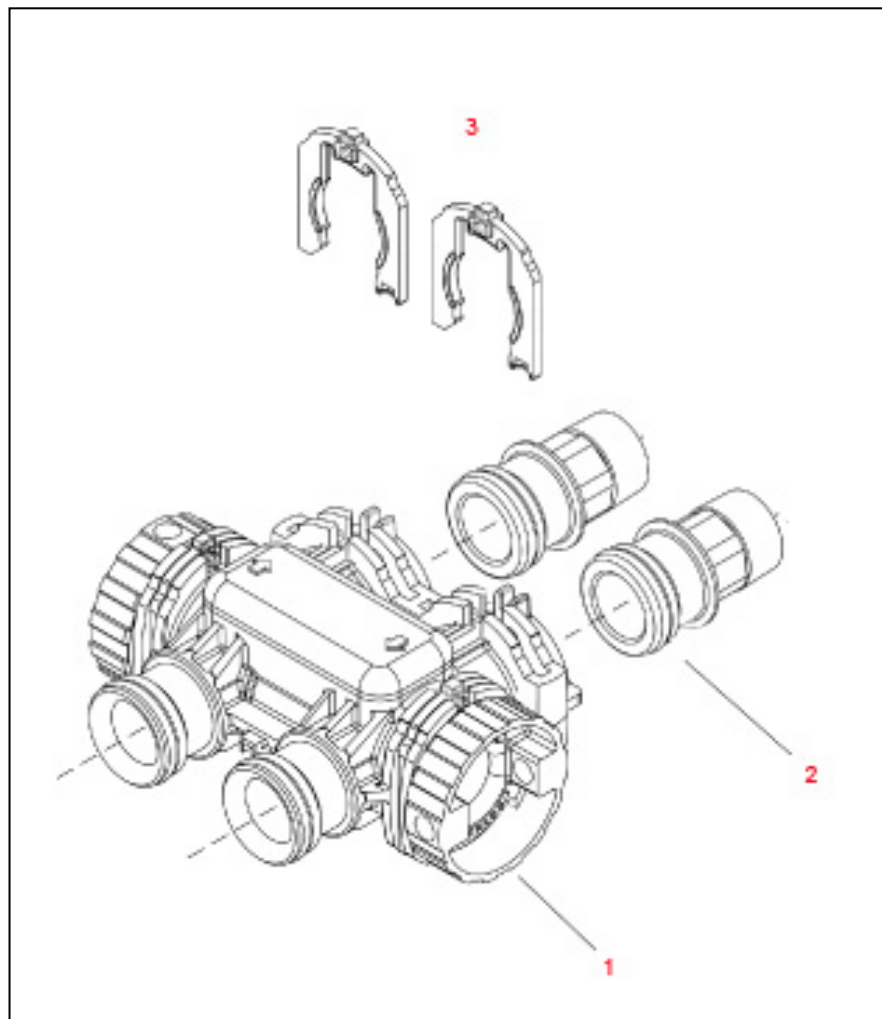

8. Lubricate the by-pass valve o-rings with some vegetable oil or silicone grease and connect the bypass assembly to the Fleck 7000 control by sliding the bypass valve firmly into the body of the Fleck 7000. Once bypass is in far enough, you will be able to insert the red connector clips.
9. Next lubricate the end-connectors with some silicone grease or vegetable cooking oil and insert them into the bypass valve and then insert the red clips.
10. Note that the Fleck 7000 is usually shipped in the bypass position. There is a bypass valve knob on both the inlet and the outlet. You can easily tell if it is in bypass because the two holes on the bypass knob will be in the vertical position. If the valve is in the Service position (by which is the filtering position or 'in service' position) the holes will be in the horizontal position. Make sure both sides are in the by-pass position.
11. In the future, do NOT remove the red clips in order to put the bypass valve in either bypass or service, it is not necessary nor desired to remove the red clips on the bypass valve hand knobs (see Fig 5 item 1, which are the knobs you will turn to move the bypass valves).
12. Now install your water pipes to the Fleck 7000 bypass end connectors. Make sure inlet is installed to the 'In" pipe connector on the bypass valve and outlet is on the "Out" connector.
13. Connect some flexible tubing from the drain connection on the Fleck 7000 control valve to a suitable drain such as a septic tank or drain to a sewer. It is OK to run the drain line up and over the Fleck 7000 greensand filter up to 4 feet above the top of the tank. If the drain line will be more than 20 feet, use larger diameter tubing such as ¾" or 1". Note that it is desirable to be able to run the drain line into a bucket in order to test the backwash flow rate in the future. This is why hard piping the drain line is discouraged, however, if you do use hard PVC piping for the drain line, and you are able to remove the hard PVC drain piping and attach flexible tubing should you ever desire for testing purposes, it is OK to use rigid PVC pipe for the drain. Make sure the drain tubing is firmly clamped to the barbed fitting with a hose clamp to prevent leaks.
14. For the 2.5 cubic foot systems only: these larger tank systems have an external stainless steel flow control that comes with the system. This must be installed. If you have a 1.0 or 1.5 cubic foot system, the flow control is internal and there is no external drain flow control.
15. Take out the float assembly and remove the rubber band installed for shipping the tank, if present on the float assembly. Re-install the float assembly. See Fig 6.
16. Next attach the potassium permanganate solution tank tubing (3/8" black poly tubing) from the permanganate solution tank to the Fleck 7000 control valve. See Fig 7 and 8. Locate the 4' length of plastic 3/8" tubing shipped inside the Pot Perm tank. As you stand in front of the Fleck 7000 control, locate the male thread Pot Perm line tube connection fitting located on the top, left hand side of the valve body and attach the tubing, do not over-tighten the nut. Attach the other end to the pot perm tank.

Fig 6 Potassium permanganate safety-float assembly



Fig 7 and 8 Attaching the perm tubing to the perm solution tank



17. Add enough clean water to the pot perm solution tank to bring water level about 1" above the felt pad. Add one 5-lb jug of potassium permanganate granules to the potassium perm tank by pouring it directly on top of the white felt pad. Do not pour permanganate down the white plastic brine well where the black line is attached.
18. See the over-flow barbed fitting on the side of the perm tank. You do not have to connect to this to a drain. If the safety float were to malfunction, there is a small chance that pot perm solution will drip out of this fitting. If this would cause a big mess where you have installed the greensand filter, hook some tubing to this and run to a bucket, floor pan or floor drain. Normally no pot perm solution will leak out of this fitting.
19. Now you are ready to turn on the water to the system. Turn on the water and leave on bypass and check for leaks. Leave the ball valve after the greensand filter closed, so water is still off to the house, but connect a garden hose and open up the hose bib after the greensand filter and allow the water to run. This will help to clear out any foreign material that may be in the pipes from the piping installation. If you do not have a valve installed after the greensand filter and you do not have a hose bib, you will need to turn the water on inside the house to let the water run. Use a bathtub or laundry sink or other fixture that does not have an aerator screen.
20. Leave the water running out of the garden hose at a slow rate. Now you can turn the bypass valve to the service position. You do NOT remove the red clips on the bypass knobs in order to turn the bypass valves from the bypass to the service position. First open the Inlet Side of the bypass valve. Second slowly open the Outlet Side of the bypass until it is in the full service position. The Fleck 7000 bypass valve knobs are a little stiff, so you can use a screw driver placed in the holes to turn the knobs. Make sure you are turning the bypass valve knobs in the correct direction which is counter-clockwise as you face the bypass valve knobs.
21. Now turn on the garden hose to full force and let the water until it turns relatively clear. The water may be dark or black at first.
22. Your Greensand 7000 control valve is already pre-programmed. All you need to do is to set the time of day, and then set the number of days the greensand filter will run before it backwashes and regenerates automatically. The default number of days between back wash is seven.
23. Start by setting the time of day by pressing the up or down arrows until it is the current time of day.
24. Hold down the up arrow and down arrow at the same time for 5 seconds. Set the time of the night that you want the greensand filter to backwash. The default time is 2:00am. Press the Extra Cycle button once. Now set the number of days between backwashes, the default is 7 days. If you have a large family and a high level of iron, you may want to set the backwash frequency to every 3 to 4 days. Now press the Extra Cycle button once more. You are done programming!

25. Your greensand media must be regenerated before you can use the water. Start a manual backwash and rinse (also called 'regeneration') by pressing or holding the Extra Cycle button for 5 seconds.
26. At this point the greensand filter will be in a backwash mode, which is the first of five cycles it goes through during regeneration. The backwash takes 10 minutes. After 10 minutes, the Fleck 7000 will begin to suck up the permanganate solution from the permanganate tank.
27. After another 10 to 15 minutes the pot perm tank will be sucked dry of the liquid potassium permanganate. Check to make sure that the pot perm tank is empty after this cycle.
28. After 60 minutes of being in this Cycle 2, referred to as the brining cycle, it will move to the next cycle, Cycle 3, which is a 5 minute second backwash cycle. The next cycle, Cycle 4 is a 10 minute rapid rinse. Finally Cycle 5 refills the pot perm tank.
29. Check to make sure at the end of the cycles that the pot perm tank is filled with enough water to cover the felt pad by approximately ½ to 1 inch for a 1.0 – 1.5 cubic foot size filter and 2 inches if you have a 2.5 cu ft size system. You can change the level of permanganate liquid by adjusting the level of the float assembly. For most users though it is not necessary to adjust the float, it comes set to the correct level.
30. After the regeneration process is complete, turn on the water to the house and run the water in the house for a few minutes.
31. Refer to your Fleck 7000 service manual for more information about how your control valve is programmed if desired.

Maintaining Your Greensand 7000 Filter System

Adding Potassium Permanganate:

Add one 5-lb jug of potassium permanganate every 3 - 4 months. Check the potassium permanganate solution tank and when you see the mound of potassium permanganate disappear after a few months, just add another 5-lb jug. In some cases, you won't see the mound, you might just see solution after a couple of weeks. This is OK, you still only need to add the potassium permanganate every 3 months in most cases. If you have it set to regenerate (backwash cycles) every 1 – 3 days, you might need to add it more frequently, perhaps every 2 months.

Clean the Injector

Once a year, clean the permanganate solution tank and the brine injector.

1. Shut off the water to the filter or put the filter on bypass.
2. Release water pressure by pressing the Extra Cycle button, or shut off the water to the house by closing the ball valve after the greensand filter, and release the pressure by opening up the hose bib after the greensand filter.
3. Pull out red clip #3 (see Fig 9) using a small flat screwdriver.
4. Pry out #8 Cap Injector to reveal #15 injector screen, and #7 injector assembly using small screw driver. Clean in vinegar or muriatic acid.
5. Re-install these items and test to make sure the injector is drawing a vacuum by removing the the 3/8" black tubing from the pot perm tank to the control valve, at the opening #9.
6. Turn the water back on and return to service position.
7. Push the Extra Cycle button. Wait 10 to 12 minutes until the Greensand 7000 control valve is in the brine draw position (Cycle 2). At this point, it should be sucking a vacuum, which you can determine by placing your thumb over the hole.
8. Note that if you do NOT want the Fleck 7000 control to go through all the cycles (which takes 90 minutes) you can press the Extra Cycle to advance to the next cycle. Wait until the 7000 control goes to the next cycle and press the Extra Cycle button again and continue until the control valve is back in the service position and displaying the current time.
9. Next clean the potassium perm tank by removing the felt pad and cleaning in muriatic acid, citric acid or vinegar, or better yet just replacing the felt pad if you want. Clean the float and rinse the pot perm tank out. Its better to use rubber gloves when you are doing this to avoid the possibility of staining your hands with potassium permanganate. If your hands do become stained you can clean them with vinegar or lemon juice.

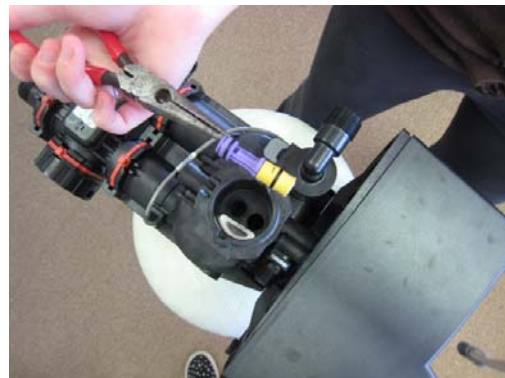
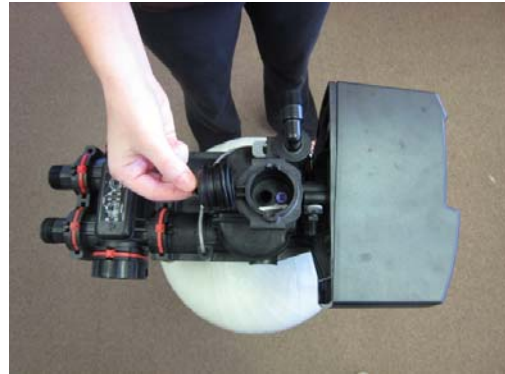

Troubleshooting the Fleck 7000 Greensand Filter

PROBLEM / SYMPTOM	POSSIBLE CAUSE	SOLUTION
<p>Iron or manganese or sulfur odor in treated water after Greensand Filter</p>	<p>No permanganate in solution tank</p> <p>Not backwashing often enough</p> <p>Water being used when Greensand Filter is in a regeneration.</p> <p>Permanganate solution is not being sucked in during the regeneration brine cycle.</p> <p>Greensand media exhausted</p>	<p>Add permanganate powder to tank and regenerate greensand filter</p> <p>Set to backwash more frequently. Backwash twice in one day and re-check water.</p> <p>If any water is used during the 90 minute regeneration cycle, untreated water will enter household piping. Set time Greensand Filter regenerates to a time when no one will be using the water.</p> <p>Clean brine injector</p> <p>Clean potassium permanganate tank</p> <p>Replace permanganate support pad in permanganate tank</p> <p>Inadequate backwash flow. Make sure there that Greensand Filter is backwashing at the correct backwash flow rate (5 to 10 gallons per minute depending on size of filter).</p> <p>Low water pressure. Increase water pressure to unit by adjusting well pump pressure switch, or replacing well pump.</p> <p>Replace Greensand media with new Greensand.</p>
<p>Strong sulfur odor before and after Greensand filter</p>	<p>High levels of hydrogen sulfide gas in well water</p>	<p>In some cases, the greensand filter may need a chlorine feed (or ozone, oxygen or other oxidizer) prior to the filter. Make sure Greensand filter is working correctly, and try regenerating it once or twice a day for one week. If odor persists, replace Greensand media or add a chlorinator ahead of the Greensand Filter.</p>

Pink water (permanganate) in household water	Inadequate backwash of Greensand Filter	Make sure Greensand Filter has adequate backwash at a good pressure and flow rate
	Clogged brine injector	Clean or replace injector
	Inadequate rinse time	Set rinse cycle to longer time
	Too much permanganate	Lower float so that level of permanganate is lower in permanganate solution tank.
Potassium permanganate tank over-filling or over-flowing	Clogged brine injector	Clean or replace injector

More Troubleshooting Tips

Potassium Permanganate Not Being Sucked In During Regeneration

Most problems occur when the Fleck 7000 is not drawing in the potassium permanganate. Make sure the injector is drawing in the potassium permanganate:

1. Remove the permanganate solution tank tubing where it enters the Fleck 7000 control valve.
2. Press the Extra Cycle button and hold for several seconds until a backwash is started. After the display stops blinking and its in a backwash cycle, press the Extra Cycle button again, and it will advance to the next cycle, which is the Brine Cycle, where it is supposed to suck in the permanganate solution.
3. If is sucking strongly, check the potassium permanganate solution tank float inside the brine well and make sure there is no rubber bands around it, and that is free of obstructions. In some cases it may need to be replaced or cleaned, if there is suction at the control valve, but no permanganate is being drawn in.
4. If there is NO suction at the control valve port where you removed the permanganate tubing, then the injector should be cleaned.
5. If the injector has been cleaned and there is still no suction check to make sure there is obstruction in the backwash line; that the backwash line does not go up and over the greensand filter more than several feet (which causes pressure loss and the injector not to work correctly); finally check to make sure there is enough pressure. If possible increase your water pressure to the iron filter from your well pump and see if a slightly increased pressure makes the injector work. We recommend a minimum 30 PSI but it does work better if there is 40 to 50 minimum PSI.

System Not Backwashing Adequately

The other second main problem that may occur is if you do not have enough backwash flow rate to properly clean the greensand filter. You can verify the backwash flow rate by running the drain line into a bucket and timing it when the Fleck 7000 is in Cycle 1 or backwash. A 1.0 or 1.5 cubic foot system should have 5 gallons per minute and a 2.5 cubic foot system should have 10 gallons per minute of backwash.

System Not Programmed Correctly – PROGRAM SETTINGS

In some cases, the Fleck 7000 may not be programmed correctly. Verify the correct programming by following these steps . **IMPORTANT Note: do NOT follow these steps if your Fleck 7000 has a flow-meter based regeneration. If you have a flow sensor, see the separate guide for programming the Fleck 7000 with a flow sensor).** Follow these steps to make sure it is set correctly:

1. Enter Master Programming by following these steps: Set the Time Of Day display to 12:01 P.M. Press the Extra Cycle button (to exit Setting Time of Day mode). Then press and hold the Up and Down buttons together until the programming icon replaces the service icon and the Display Format screen appears.
2. DF GAL (this stands for US gallons format, if it is different change by using the up or down arrow). Press the extra cycle button one time.
3. VT: that display should be set to: “St2b”. If it is different, use the up or down arrow to reset to dF which is the correct setting. Press the extra cycle button one time.
4. CT: set to ‘tc” (stands for time-clock delayed regeneration). Press the extra cycle button one time.
5. DO : Stands for Day OverRide. This is tells the greensand filter how often to regenerate in days. It can be set for any setting from 1 to 7, with 4 being the recommended common setting . If you are having some problems with iron bleed-through after the filter has been online for a few days you may want to change it to 2 or 3 days. Press the extra cycle button one time.
6. RT **Set to 2:00 am** generally or sometime when no water is being used, and no other filter or softener is likely to be in a regeneration cycle. Press the Extra Cycle button.
7. BW – Stands for BackWash length in minutes. 1 – 10 refers to 10 minutes of backwash. If your water is extremely high in iron you can change this setting to 12 or 14 minutes to allow some extra backwash time, but 10 minutes is a good setting. Press the extra cycle button one time
8. BD – stands for Brine Draw. This is the cycle where solution is sucked in from the POT PERM Solution tank, and if bleach is in the tank, will chlorinate and clean the filter media with

chlorine bleach. This cycle is 60 minutes long and should display: 2 – 60. Press the extra cycle button one time.

9. BW - This cycle is a second backwash and will clean the media of any residual chlorine. This cycle should display: 3 – 5. Press the extra cycle button one time.
10. RR – This is the Rapid Rinse cycle and should display: 4 – 8. Press the extra cycle button one time
11. BF - This is the Brine Fill, where the potassium permanganate is refilled with water to make solution for the next cycle. . This should display: 5 -12. This mean it the cycle will last for 12 minutes. This final cycle adds water to the POT PERM solution tank. Press the extra cycle button one time.
12. It will read: LF60 This refers to 60 hz electrical power which is we have in the U.S. If you are in a different country and use 50hz you can change it here.
13. Press the extra cycle button one time to return to the time of day and in-service position.

Potassium Permanganate Tank with Float

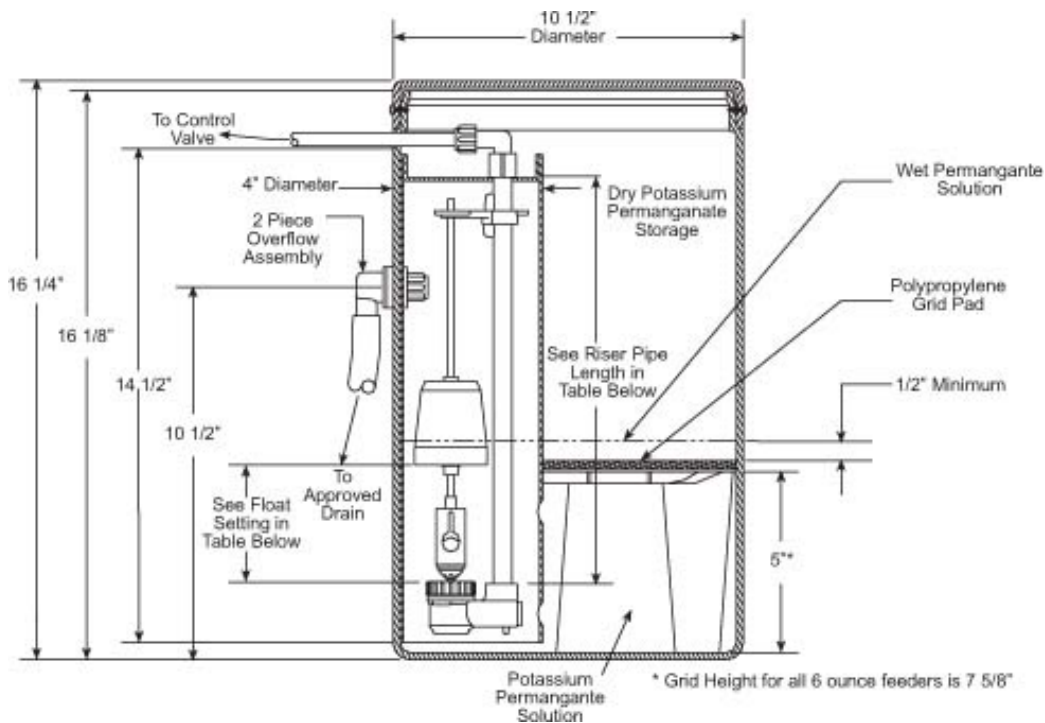

Permanganate tank not filling with permanganate solution

Potassium permanganate is a powder that is poured on top of the “grid pad” in the pot perm tank. During the brine fill cycle, water is added to the pot perm tank to make up the pot perm solution required for the next regeneration.

If your pot perm does not have ½” to 1” of solution above the grid pad, the first to check is to make sure it is filling the tank:

1. Disconnect the 3/8” black poly line at the pot perm tank or at the control valve.
2. Put control valve into a REGEN cycle by seeing Page 14 “Program Settings”. You can advance to the Brine Fill cycle by pressing Extra Cycle button again, to skip through the cycles. Advance to the BF cycle.
3. If it IS filling, remove the safety float and make sure the air check ball is moving free and not stuck. A stuck float is often the cause of this problem and can be easily fixed. If the float is defective or older than 5 years, replace float.
4. If it is NOT filling during the Brine Fill (BF) cycle, then make sure there is enough minutes. It should be set for 12 minutes for standard size Clack pot perm tanks. If you have a larger commercial size tank, set for 20 minutes.
5. If it is still not filling, the brine valve may need to be cleaned. In the Fleck 7000 SXT manual, in the diagram “Valve Assembly” see the part 9, which is the brine drain line flow control. Clean this first. If there is still a problem and it is not filling, clean and/or replace the brine valve 5.

