



Clean Water Made Easy

www.cleanwaterstore.com

Fleck 5600-SXT Softener Installation & Start-Up Guide

Thank you for purchasing a Clean Water System! With proper installation and a little routine maintenance your system will be providing filtered water for many years.

Your new system comes with a printed Fleck Service manual, which along with this start-up guide will help guide you in the installation and start-up of your new system. The Fleck service manual covers other types of systems as well such as water softeners and filters, so there may be information in your Fleck service manual that does not pertain to your system. Please review this start-up guide entirely before beginning to install your system and follow the steps outlined for best results.



Questions?

Call us toll-free: 1-888-600-5426 or 1-831-462-8500

Email us: support@cleanwaterstore.com

See more information on our website: www.cleanwaterstore.com/resources



Clean Water Made Easy

www.cleanwaterstore.com

Table of Contents

Packing List	2
Pre-Installation	3
Best Practices for Piping & Drain Installation.....	3
How Your Softener Works.....	4
Installation Instructions.....	7
Attaching the brine line tubing to the brine tank & the Fleck 5600-SXT brine valve.....	9
Maintaining Your Softener 5600-SXT System	13
Replacing Brine Valve, Injectors and Screen	13
Brine Valve Replacement	13
Injectors/Screen Replacement	14
Troubleshooting the Fleck 5600-SXT Softener.....	14
More Troubleshooting Tips	16
Brine Solution Not Being Sucked In During Regeneration	16
System Not Backwashing Adequately	17
System Not Programmed Correctly – PROGRAM SETTINGS	17
Brine Tank Not Filling With Enough Water	17
Filter Tank Does Not Sit Level on the Floor	17

Fleck 5600-SXT Softener Installation & Startup Guide

Packing List

All models will come with:

Quantity	Description
1	Fleck 5600-SXT backwash control valve & bypass valve
1	Pipe connector kit (either 1" or ¾")
1	Black brine tank
1	Media funnel

You will also receive one of the following groups of items depending on the size of your system.

Model Size: 24K Grain Softener:

Quantity	Description
1	8" x 44" filter tank with distributor tube
1	¾ cubic foot box of softening media (resin)

Model Size: 32K Grain Softener:

Quantity	Description
1	9" x 48" filter tank with distributor tube
1	1 cubic foot box of softening media (resin)

Model Size: 48K Grain Softener:

Quantity	Description
1	10" x 54" filter tank with distributor tube
1	1 cubic foot box of softening media (resin)
1	½ cubic foot box of softening media (resin)

Model Size: 64K Grain Softener:

Quantity	Description
1	12" x 52" filter tank with distributor tube
2	1 cubic foot boxes of softening (resin)

Model Size: 80K Grain Softener:

1	13" x 54" filter tank with distributor tube
2	1 cubic foot box of softening media (resin)
1	½ cubic foot box of softening media (resin)

*NOTE: All Fine Mesh Resin Softeners will come with a box of gravel (does not include SST60 resin)

Pre-Installation

1. Review your packing list and make sure you have received all the parts before beginning installation. Please ensure that all parts are included before scheduling a plumber or installer to come to the site.
2. If you are going to be turning off the water to the house and you have an electric water heater, shut off the power to the water heater before beginning installation in case water heater is accidentally drained.
3. Pick a suitable location for your filter system on a dry level spot where it won't be exposed to freezing temperatures. A minimum of 20 PSI is required. Maximum pressure is 90 PSI.
4. Get all of your plumbing parts together before beginning installation. Installation typically takes 3 to 5 hours. However after installation the Softener must be allowed to run through a complete backwash and rinse cycle (also called 'regeneration'). You don't have to be present for this first backwash necessarily, but it does take 90 minutes.
5. After the system is installed and running, your water may be discolored, or full of sediment or rust, particularly if this is older piping that has been exposed to iron or manganese for some time. Typically this clears up over a day or two, but can persist for weeks if the pipe is old galvanized iron pipe that is corroded.

Best Practices for Piping & Drain Installation

1. See typical installation (see Fig 1). The softener is installed after the pressure tank.
2. Make sure to connect the inlet pipe to the Fleck 5600-SXT inlet and the outlet to the outlet (see Fig 2). As you face the Fleck 5600-SXT control from the front, the water enters on the right and exits on the left. From the back (see Fig 2) the water enters on the left. The inlet and outlet are attached to the bypass valve which is marked with arrows as well.
3. Make sure there is a working gate or ball valve before the Fleck 5600-SXT Softener and also one after as shown in the diagram. The pressure gauges are optional and not necessary but a hose bib (which is a faucet that you can attach a garden hose to) is strongly recommended after the softener before the second ball valve. This makes it easy to rinse your new softener on start-up and gives you a place to test the water before it enters your household plumbing.
4. If you will be using copper piping, do not sweat the copper pipe directly on to the Fleck 5600-SXT control valve. Avoid heating up the Fleck 5600-SXT control valve plastic with the torch.

5. You do not need unions to install your Fleck 5600-SXT control. If you need to remove it, the Fleck 5600-SXT has quick-release couplings that make it easy to put the softener on by-pass and remove the filter system from the piping.
6. The drain line tubing (not supplied) is connected to a drain from the drain outlet using flexible ½" ID tubing. Note that the drain can run up above the Fleck 5600-SXT control and into a drain, it does not have to drain down, as the filter backwashes under line pressure from your well pump. Most plumbing codes require an air-gap connection, so that if your sewer or septic tank backs up, it cannot cross connect with the drain tubing.

How Your Softener Works

See Fig 1. In the softener, the water enters the top of the tank and flows down through the media and up the distributor tube. Hardness minerals are drawn to the resin beads in the softener. During backwash, the water flow is reversed and water flows down the distributor tube and up through the media, lifting and expanding the softening media, and removing any trapped particles in the media. After the backwash stage, salt brine automatically drawn in from the brine tank and slowly rinses through the softening resin for 1 hour, which allows the hardness minerals to be swapped out with harmless sodium or potassium ions. This entire automatic process, called 'regeneration' takes about 90 minutes. Typically the softener filter is set to regenerate every 14-21 days, during the middle of the night when no water is being used.

Fig 1

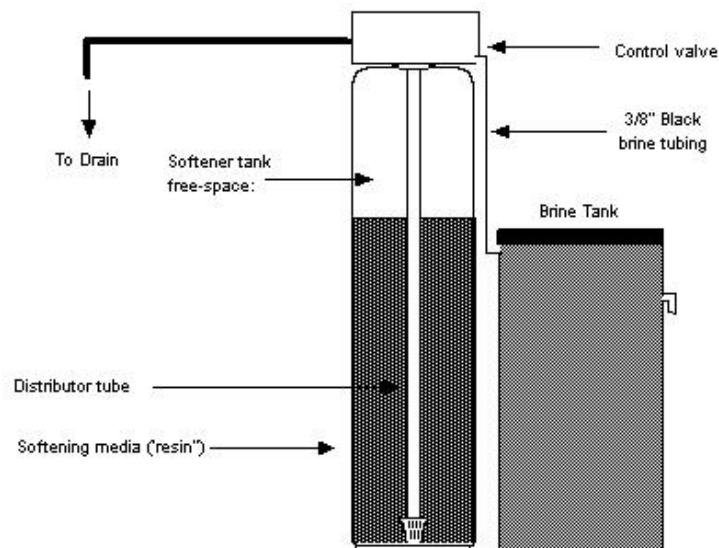

Fleck 5600-SXT Softener Installation & Startup Guide

Fig 2 - Typical Softener Fleck 5600-SXT piping installation with ball valve and hose bib after the filter along with pre- and post-filtration if necessary:

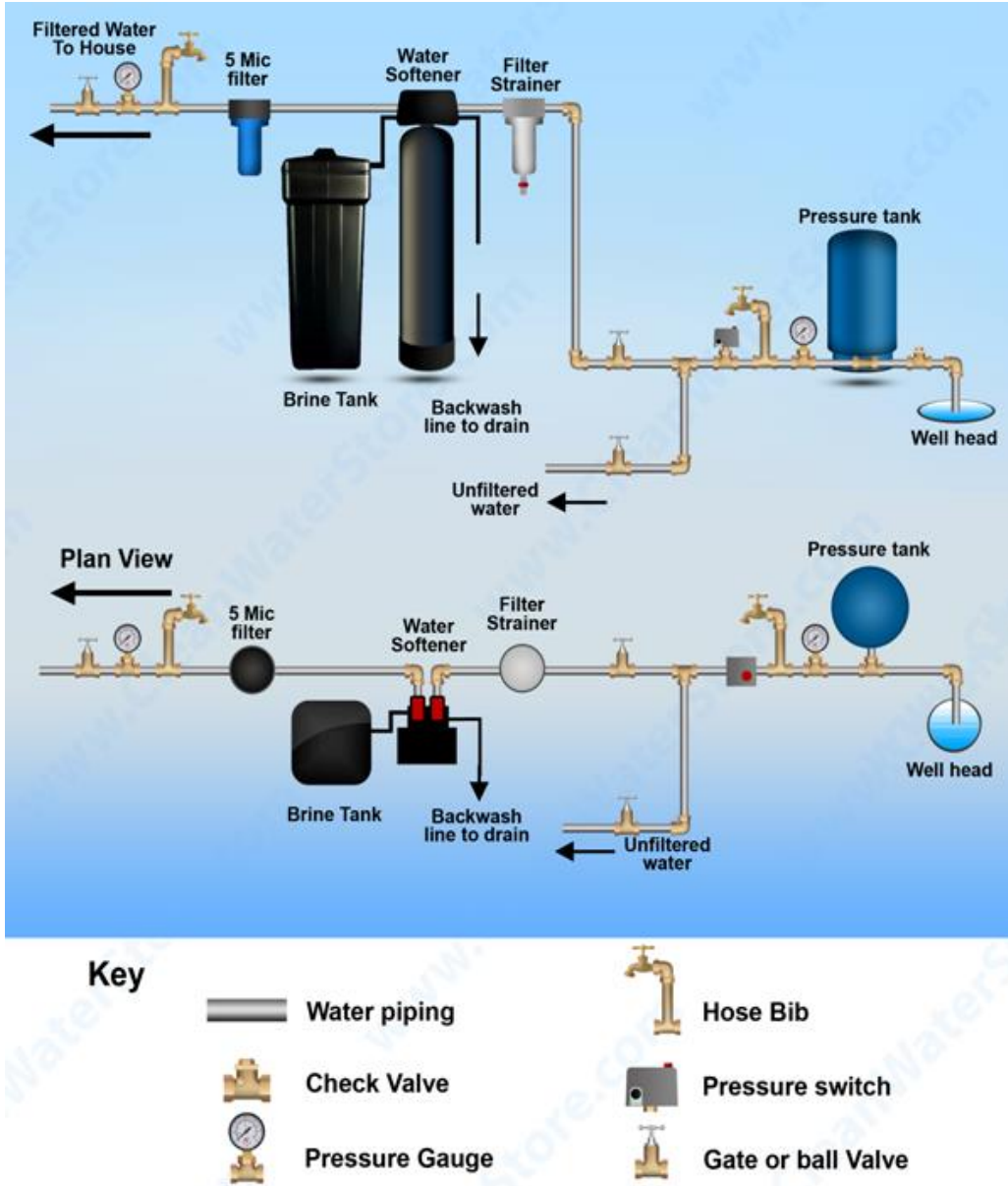

Fleck 5600-SXT Softener Installation & Startup Guide

Fig 3: Fleck 5600-SXT from the rear showing the inlet and outlet end-connector fittings 1" or 1-1/4" NPT in Noryl plastic. Brass end-connectors are also available for connecting to copper tubing.

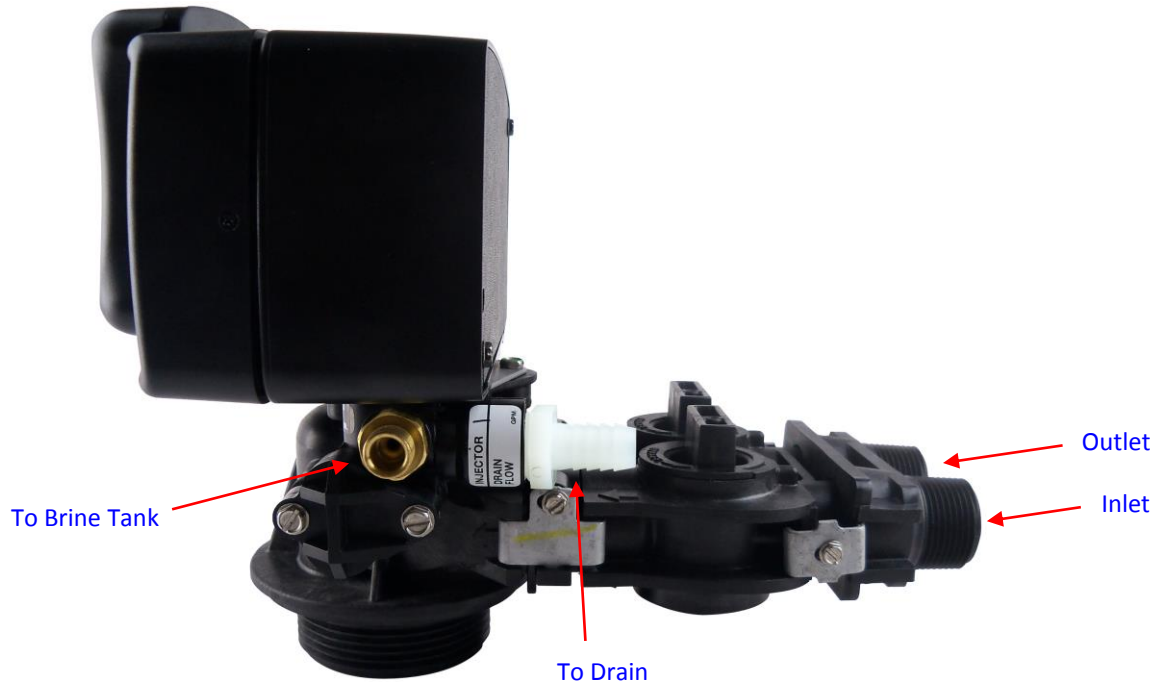

Fig 4 Fleck 5600-SXT top view



Installation Instructions

1. Unscrew by hand the entire Fleck 5600-SXT control valve from top of tank if it was shipped screwed on. Place distributor tube in tank if not already inside tank. If not already done, make sure blue cap is on top of distributor tube, or wrap the top of distributor tube with electrical or duct tape. The idea is we do not want any media to go down the distributor tube.

Plug or tape top of distributor tube when adding media to prevent media from entering. Remove when finished.



2. Next add the softening resin using the media funnel provided. If you purchased a Fine Mesh Resin Softener add the included gravel first. Tank will be approximately 2/3 to the 3/4 full.
3. Remove cap or tape from top of distributor tube. Be careful not to pull up distributor tube when removing cap or tape.
4. Attach plastic top screen to the under-side of the Fleck 5600-SXT control valve. It is a funnel-shaped plastic screen that snaps on to the control valve and prevents resin from being backwashed out to drain during the regeneration cycles.

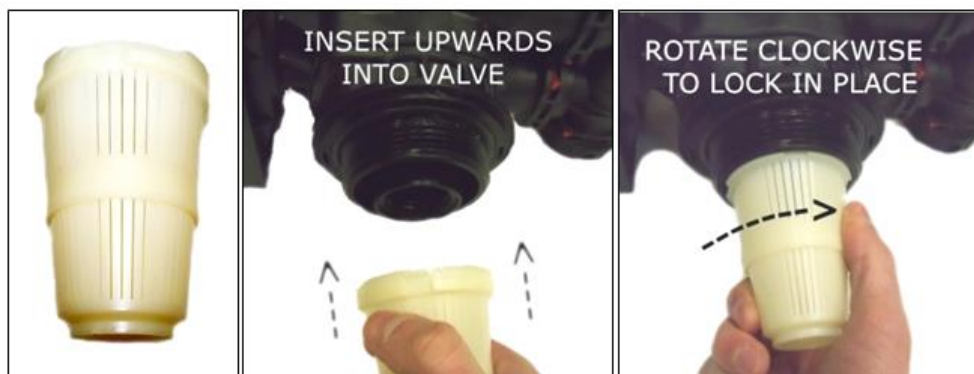

- NOTE Regarding Teflon tape and pipe sealants: It is OK to use Teflon tape and pipe sealant on the water pipe connector threads, where you attach your pipes or plumbing to the Fleck 5600-SXT. DO NOT USE any Teflon tape or pipe joint compound on the tank itself or on the threads where the Fleck 5600-SXT threads into the tank.
- Install the Fleck 5600-SXT backwash control-timer valve on to the top of the filter tank by hand, do not over-tighten. Tighten by hand, there is no need for a pipe wrench or other wrench.
- See the bypass image below. Note that Item 2 is the plastic pipe connector yoke. Items 3 are the metal clips that hold the pipe connector yoke onto the bypass valve. To put system on or off bypass just turn the knobs (1). Fleck 5600-SXT is usually shipped in by-pass position. Leave in bypass position for now.

Fleck 5600-SXT Bypass (1) & Pipe Connectors (2)

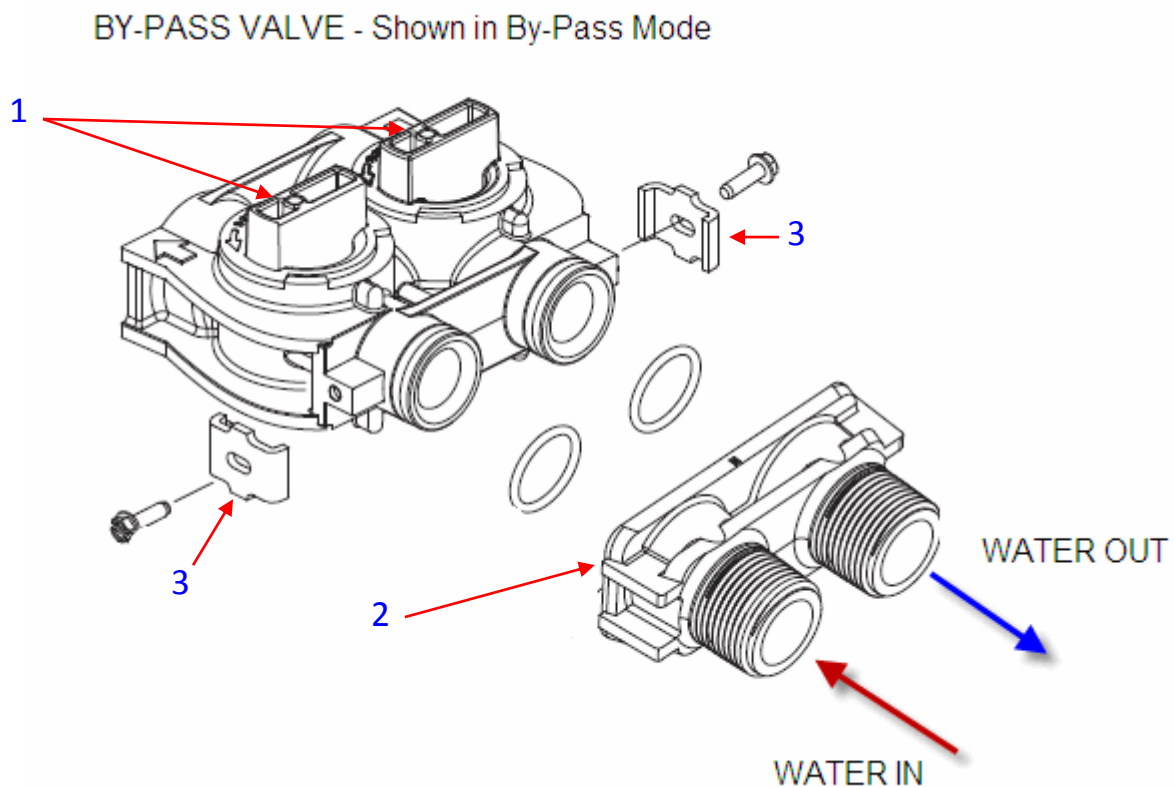

8. Lubricate the by-pass valve o-rings only on the pipe connectors with some vegetable oil or silicone grease and connect the bypass assembly to the Fleck 5600-SXT control by sliding the bypass valve firmly into the body of the Fleck 5600-SXT. Once bypass is in far enough, you will be able to easily insert the red connector clips. **DO NOT USE OIL OR PETROLEUM GREASE ON ANY PART OF THE FLECK 5600-SXT CONTROL VALVE.** O-rings are OK to lubricate but not the main tank threads.
9. Make sure the by-pass valve is in the bypass position when starting the installation. Follow the IN and OUT arrows on the bypass valve and control valve for proper connection of in and out water piping. Leave in the BY-PASS position for now.
10. Now install your water pipes to the Fleck 5600-SXT bypass end connectors. Our preferred method is to wrap the pipe threads with 2 or 3 wraps of Teflon tape, then apply a thin coating of white non-hardening Teflon joint compound paste (available at all hardware stores) before attaching the pipe fittings. Make sure inlet is installed to the 'In' pipe connector on the bypass valve and outlet is on the "Out" connector. **Note:** Arrows on bypass valve should be visible from the top of the bypass valve.
11. Connect some flexible tubing from the drain connection on the Fleck 5600-SXT control valve to a suitable drain such as a septic tank or drain to a sewer. It is OK to run the drain line up and over the Fleck 5600-SXT Softener up to 4 feet above the top of the tank. If the drain line will be more than 20 feet, and especially if your system is a 2.0 or 2.5 cubic foot size, use larger diameter tubing such as $\frac{3}{4}$ " or 1". Note that it is desirable to be able to run the drain line into a bucket in order to test the backwash flow rate in the future. This is why hard piping the drain line is discouraged, however, if you do use hard PVC piping for the drain line, and you are able to remove the hard PVC drain piping and attach flexible tubing should you ever desire for testing purposes, it is OK to use rigid PVC pipe for the drain. Make sure the drain tubing is firmly clamped to the barbed fitting with a hose clamp to prevent leaks.
12. Next, connect the solution tank to the Fleck 5600-SXT control valve with the black tubing, provided with the brine tank.

Attaching the brine line tubing to the brine tank & the Fleck 5600-SXT brine valve



Fleck 5600-SXT Softener Installation & Startup Guide

13. Begin by sliding the plastic brine injector nut on to the brine tubing by putting the tubing through the non-threaded side of the nut. Next, slide the black (or clear) compression ring on to the tubing with the narrower diameter going on first. Then slide the taller, white compression ring on to the tubing with the wider diameter going on first. The two compression rings should lay flush against each other on the tubing. Slide them in to the brine injector nut and place the brine tubing into the brine valve. Finally, push the brine injector nut, which now has the compression rings inside of it, on to the threading of the brine valve and rotate the nut clockwise, screwing it on to the brine valve. Tighten it down to finger tightness. The tubing should be firmly attached and not slide out if pulled on.
14. Repeat step 14 to attach the tubing to the perm solution tank. This uses the same process, but on the brine tank valve.



Or it may need to be installed like this, with the tube going through, depending on the design (below).

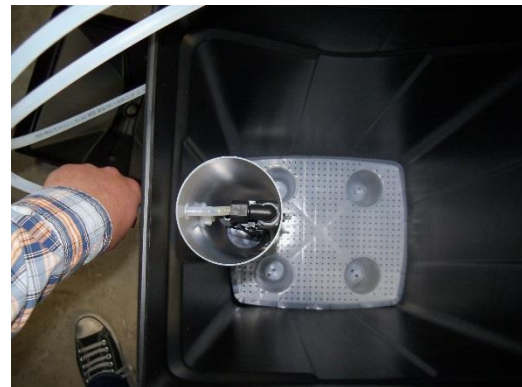
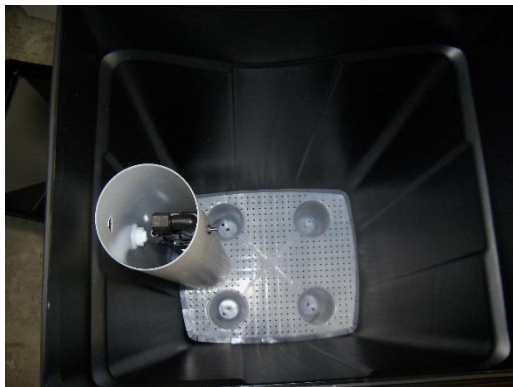

15. Add approximately 5 gallons of water to the brine tank, and then fill the brine tank about 2/3 full of salt. It is OK to use any kind of water softening salt, however we find that extra coarse salt works better than pellets. You do not have to add water to the brine tank again after this first time during the start-up.
16. See the over-flow barbed fitting on the side of the brine tank. You do not have to connect this to a drain. If the safety float were to malfunction, there is a small chance that the brine solution will drip out of this fitting. If this would cause a big mess where you have installed the softener, hook some tubing to this and run to a bucket, floor pan or floor drain. Normally no brine will leak out of this fitting.

17. Now you are ready to turn on the water to the system. Turn on the water and leave on bypass and check for leaks. Leave the ball valve after the softener closed, so water is still off to the house, but connect a garden hose and open up the hose bib after the softener and allow the water to run. This will help to clear out any foreign material that may be in the pipes from the piping installation. If you do not have a valve installed after the softener and you do not have a hose bib, you will need to turn the water on inside the house to let the water run. Use a bathtub or laundry sink or other fixture that does not have an aerator screen.
18. Leave the water running out of the garden hose at a slow rate. Now you can turn the bypass valve to the service position. You do NOT remove the red clips on the bypass knobs in order to turn the bypass valves from the bypass to the service position. First open the Inlet Side of the bypass valve. Second slowly open the Outlet Side of the bypass until it is in the full service position. The Fleck 5600-SXT bypass valve knobs are a little stiff, so you can use a screw driver placed in the holes to turn the knobs. Make sure you are turning the bypass valve knobs in the correct direction which is counter-clockwise as you face the bypass valve knobs.
19. Now turn on the garden hose to full force and let the water until it turns relatively clear. The water may have some color at first.
20. Your Softener 5600-SXT control valve does require some modifications to the programming specific to your application. To enter the programming mode, you just need to set the time to **12:01 PM**. To do this, hold either the up or down button until the time display starts changing. Then push the extra cycle button to exit the time-setting mode.
21. Next, hold down the up arrow and down arrow at the same time for 5 seconds. This will enter you into the Master Programming Mode. Change the parameters according to the following guide
22. **Display Format (Display Code DF): Set display to GAL** (stands for U.S. Gallons), or change to Liters or Cubic Meter is outside the U.S. Press the Extra Cycle button to go to the next step
23. **Valve Type (Display Code VT): Set to DF1b**. This means it is set for standard Downflow mode. Press the Extra Cycle button to go to the next step.
24. **Control Type (Display Code CT): Set to Fd**. This is the Meter Delayed option. This tells the Fleck 5600-SXT control to meter or keep track of the amount of water used, but then wait until the pre-set regeneration (backwash and rinse cycles) time, typically in the middle of the night. Press the Extra Cycle button to continue.
25. **Unit Capacity (Display Code C): Set to 32 if you have a 32K grain capacity softener; 48 if you have a 48K grain softener, 64 if you have a 64K grain softener, or 80 if you have an 80K grain softener.** Use this display to set the Unit Capacity. This setting specifies the treatment capacity of the unit. Press the Extra Cycle button to go to the next step.
26. **Number of Tanks (Display Code N): Set to 1**, as this is a single-tank system. Press the Extra Cycle button.

27. **Feedwater Hardness (Display Code H): Set to your water hardness in grains per gallon.** This is the feed water hardness that allows the meter to calculate the number of gallons between backwashes. If your water hardness is 10 grains per gallon for example, set this to 10. If your water test shows the hardness in PPM or mg/L, then divide this number 17.1 to reach grains per gallon. 1 grain per gallon = 17.1 PPM or mg/L of hardness.
28. **Reserve Selection (Display Code RS): Set to SF.** This stands for "Safety Factor."
29. **Safety Factor (Display Code SF): Set to 10.** This tells the softener to regenerate sooner by 10% of its capacity to avoid completely exhausting the softener resin before it needs to regenerate.
30. **Day Override (Display Code DO): Set to 7 to 14.** Use the Up or Down arrows to change the setting. This will allow the softener to regenerate once every 7 to 14 days no matter how much water is used. This is optional (can be set to 0) but it can be useful if you have iron or other sediment to keep the softener clean. Press the Extra Cycle button to continue.
31. **Regeneration Time (Display Code RT): Set to 2:00 am** generally or to some time when no water is being used, and no other filter or softener is likely to be in regeneration cycle. Press the Extra Cycle button to go to the next step.
32. **Regeneration Cycle Step Times:** Use this display to set the various minutes of each cycle. Use the Up or Down arrows to change the setting to the desired setting. Press the Extra Cycle button to accept the setting and move to the next parameter.
 - a. **B1 – Backwash: Set to 8 minutes.**
 - b. **BD – Brine Draw: Set to 60**
 - c. **B2 – 2nd Backwash: Set to 6 minutes.**
 - d. **RR – Rapid Rinse: Set to 6 minutes.**
 - e. **BF – Brine Fill:** For 32K grain softeners set to 12 minutes; 48K grain softeners set to 20 minutes; 64K grain softeners set to 26 minutes; 80K grain softeners set to 32 minutes.
33. **Flow Meter Type (Display Code FM): Set to T0.7.** Press the Extra Cycle Button.
34. You are now done with setting the programming. All you have to do now is set the clock to the right time of day by holding the Up or Down arrow.
35. Your softening media must be regenerated before you can use the water. Start a manual backwash and rinse (also called 'regeneration') by pressing or holding the Extra Cycle button for 5 seconds.
36. At this point the softener will be in a backwash mode, which is the first of five cycles it goes through during regeneration. The backwash takes 8 minutes. After 8 minutes, the Fleck 5600-SXT will begin to suck up the brine solution from the brine tank.
37. After another 10 to 15 minutes the brine tank will be sucked dry of the salt brine. Check to make sure that the brine tank has no water after this cycle.

38. After 60 minutes of being in this Cycle 2, referred to as the brining cycle, it will move to the next cycle, Cycle 3, which is a 6 minute second backwash cycle. The next cycle, Cycle 4 is a 6 minute rapid rinse. Finally Cycle 5 refills the brine tank.
39. Check to make sure at the end of the cycles that the brine tank is filled with enough water to cover salt. You can change the level of the brine by adjusting the level of the float assembly. For most users though it is not necessary to adjust the float, it comes set to the correct level.
40. After the regeneration process is complete, turn on the water to the house and run the water in the house for a few minutes.
41. Refer to your Fleck 5600-SXT service manual for more information about how your control valve is programmed if desired.

Maintaining Your Softener 5600-SXT System

Adding Salt to the Brine Tank:

Be sure to check the level of salt every few months (typically 3-4 months). You will see that the salt level will drop after a certain period of time based on your usage, at which point you will want to add more salt as you did the first time.

Replacing Brine Valve, Injectors and Screen

1. Turn off water supply to conditioner:

If the conditioner installation has a “three valve” bypass system, first open the valve in the bypass line, then close the valves at the conditioner inlet and outlet.

If the conditioner has an integral bypass valve, put it in the Bypass position.

If there is only a shut-off valve near the conditioner inlet, close it.

2. Relieve water pressure in the conditioner by stepping the control into the Backwash position momentarily. Return the control to the In Service position.
3. Unplug electrical cord from outlet.
4. Disconnect brine tube and drain line connections at the injector body.
5. Remove the two injector body mounting screws. The injector and brine module can now be removed from the control valve. Remove and discard brine body O-rings.

Brine Valve Replacement

1. Pull brine valve from injector body. Also remove and discard O-ring at bottom of brine valve hole.
2. Apply silicone lubricant to new O-ring and reinstall at bottom of brine valve hole.
3. Apply silicone lubricant to O-ring on new valve assembly and press into brine valve hole. Be sure shoulder on bushing is flush with injector body.

Injectors/Screen Replacement

1. Remove injector cap and screen, discard O-ring. Unscrew injector nozzle and throat from injector body.
 2. Screw in new injector throat and nozzle, be sure they are sealed tightly. Install a new screen.
 3. Apply silicone lubricant to new O-ring and install around oval extension on injector cap.
 4. Apply silicone lubricant to three new O-rings and install over three bosses on injector body.
 5. Insert screws through injector cap and injector. Place this assembly through hole in timer housing and into mating holes in the valve body. Tighten screws.
 6. Reconnect brine tube and drain line.
 7. Return bypass or inlet valve to normal In Service position. Water pressure automatically builds in the conditioner.
- NOTE: Be sure to shut off any bypass line.**
8. Check for leaks at all seal areas. Check drain seal with the control in the Backwash position.
 9. Plug electrical cord into outlet.
 10. Set Time Of Day and cycle the control valve manually to assure proper function. Make sure control valve is returned to the In Service position.
 11. Be sure there is enough salt in the brine tank.
 12. Start regeneration cycle manually if water is hard.

Troubleshooting the Fleck 5600-SXT Softener

PROBLEM / SYMPTOM	POSSIBLE CAUSE	SOLUTION
Water softener fails to regenerate	Electrical service to unit has been interrupted	Assure permanent electrical service (check fuse, plug, pull chain, or switch)
	Timer is defective	Replace timer
	Power failure	Reset time of day
Hard water	By-pass valve is open	Close by-pass valve.
	No salt is in brine tank	Add salt to brine tank and maintain salt level above water level.
	Injector screen plugged.	Clean injector screen
	Insufficient water flowing into brine tank.	Check brine tank fill time and clean

Fleck 5600-SXT Softener Installation & Startup Guide

		brine line flow control if plugged
	Hot water tank hardness.	Repeated flushings of the hot water tank is required.
	Leak at distributor tube.	Make sure distributor tube is not cracked. Check O-ring and tube pilot.
	Internal valve leak	Replace seals and spacers and/or piston.
Unit used too much salt	Improper salt setting.	Check salt usage and salt setting
	Excessive water in brine tank.	See problem 7.
Loss of water pressure	Iron buildup in line to water conditioner	Clean line to water conditioner.
	Iron buildup in water conditioner.	Clean control and add mineral cleaner to mineral bed. Increase frequency of regeneration.
	Inlet of control plugged due to foreign material broken loose from pipes by recent work done on plumbing system.	Remove piston and clean control
Loss of softening resin through drain line	Air in water system	Assure that well system has proper air eliminator control. Check for dry well condition.
	Improperly sized drain line flow control.	Check for proper drain rate.
Iron in conditioned water	Fouled mineral bed.	Check backwash, brine draw, and brine tank fill. Increase frequency of regeneration. Increase backwash time.
Excessive water in brine tank	Plugged drain line flow control	Clean flow control
	Plugged injector system	Clean injector and screen.
	Timer not cycling	Replace timer
	Foreign material in brine valve	Replace brine valve seat and clean valve.
	Foreign material in brine line flow control.	Clean brine line flow control
Softener fails to draw brine	Drain line flow control is plugged	Clean drain line flow control
	Injector is plugged.	Clean injector
	Injector screen plugged	Clean screen

	Line pressure is too low	Increase line pressure to 20 psi (1.3 bar)
	Internal control leak	Change seals, spacers, and piston assembly.
	Service adapter did not cycle.	Check drive motor and switches.
Control cycles continuously	Misadjusted, broken, or shorted switch	Determine if switch or timer is faulty and replace it, or replace complete power head.
Drain flows continuously	Valve is not programming correctly.	Check timer program and positioning of control. Replace power head assembly if not positioning properly.
	Foreign material in control.	Remove power head assembly and inspect bore. Remove foreign material and check control in various regeneration positions
	Internal control leak.	Replace seals and piston assembly.

More Troubleshooting Tips

Brine Solution Not Being Sucked In During Regeneration

Most problems occur when the Fleck 5600-SXT is not drawing in the brine. Make sure the injector is drawing in the brine:

1. Remove the brine tank tubing where it enters the Fleck 5600-SXT control valve.
2. Press the Extra Cycle button and hold for several seconds until a backwash is started. After the display stops blinking and it is in a backwash cycle, press the Extra Cycle button again, and it will advance to the next cycle, which is the Brine Cycle, where it is supposed to suck in the brine solution.
3. If it is sucking strongly, check the brine tank float inside the brine well and make sure there are no rubber bands around it, and that it is free of obstructions. In some cases it may need to be replaced or cleaned, if there is suction at the control valve, but no brine is being drawn in.
4. If there is NO suction at the control valve port where you removed the brine line tubing, then the injector should be cleaned.
5. If the injector has been cleaned and there is still no suction check to make sure there is obstruction in the backwash line; that the backwash line does not go up and over the softener more than several feet (which causes pressure loss and the injector not to work correctly); finally check to make sure there is enough pressure. If possible increase your water pressure to softener from your well pump and see if a slightly increased pressure makes the injector work. We recommend a minimum 30 PSI but it does work better if there is 40 to 50 minimum PSI.

System Not Backwashing Adequately

The other second main problem that may occur is if you do not have enough backwash flow rate to properly clean the water softener. You can verify the backwash flow rate by running the drain line into a bucket and timing it when the Fleck 5600-SXT is in Cycle 1 or backwash. A 1.0 or 1.5 cubic foot system should have 5 gallons per minute and a 2.5 cubic foot system should have 10 gallons per minute of backwash.

System Not Programmed Correctly – PROGRAM SETTINGS

In some cases, the Fleck 5600-SXT may not be programmed correctly. Verify the correct programming by following the steps 21-33 earlier in the start-up guide.

Brine Tank Not Filling With Enough Water

Sometimes if the brine tank is not filling adequately, it is possible that the float assembly in the tank is set too low. You would want the float to be several inches above the air check valve inside the tank. This will allow for enough water to be added to the tank before shutting the brine fill cycle. If necessary, pull the float assembly rod up to the appropriate height, and cut the rod at that height, leaving while keeping the rubber washers the adequate space to hold the float in place.

Filter Tank Does Not Sit Level on the Floor

Your black filter tank base is not glued to the bottom of your tank. Occasionally tank bases will become crooked during shipment. If you find that that your tank does not sit level on the floor, you can easily adjust it by holding the empty tank and rapping it on a concrete or solid floor once or twice in order to level it.