

Fleck 2510-SXT Catalox Installation & Start-Up Guide

For Catalox Filters with PotPerm – Bleach Solution Tank

Thank you for purchasing a Clean Water System! With proper installation and a little routine maintenance your system will be providing iron free water for many years.

Your new system comes with a printed Fleck Service manual, which along with this start-up guide will help guide you in the installation and start-up of your new system. The Fleck service manual covers other types of systems as well such as water softeners and filters, so there may be information in your Fleck service manual that does not pertain to your system. Please review this start-up guide entirely before beginning to install your system and follow the steps outlined for best results.

CATALOX MEDIA CONTAINS DUST. USE PAPER MASK AND VENTILATE TO AVOID BREATHING DUST.



2806-C Soquel Ave Santa Cruz CA 95062

For assistance call: 1-831-462-8500

Email us: office@cleanwaterstore.com

More information online: www.cleanwaterstore.com

Quantity	Description
1	Fleck 2510-SXT Backwash Control Valve
1	Pipe connector kit (either 1" or ¾")
1	Fleck 2510-SXT Bypass valve
1	Enpress filter tank with distributor tube installed
1	Media funnel
1	12 lbs Gravel
2	½ cubic foot boxes of Catalox (MANG-OX) filter media

1.5 Cubic Foot Catalox:

Quantity	Description
1	Fleck 2510-SXT Backwash Control Valve
1	Pipe connector kit (either 1" or ¾")
1	Fleck 2510-SXT Bypass valve
1	Enpress filter tank with distributor tube installed
1	16 lbs Gravel
3	½ cubic foot boxes of Catalox (MANG-OX) filter media

2.5 Cubic Foot Catalox:

Quantity	Description
1	Fleck 2510-SXT Backwash Control Valve
1	Pipe connector kit (either 1" or ¾")
1	Fleck 2510-SXT Bypass valve
1	Enpress filter tank with distributor tube installed
1	Media funnel
1	20 lbs Gravel
5	½ cubic foot boxes of Catalox (Catalox) filter media

Pre-Installation

1. Review your packing list and make sure you have received all the parts before beginning installation.
2. If you are going to be turning off the water to the house and you have an electric water heater, shut off the power to the water heater before beginning installation in case water heater is accidentally drained.
3. Pick a suitable location for your filter system on a dry level spot where it won't be exposed to freezing temperatures. A minimum of 20 PSI is required. Maximum pressure is 90 PSI.
4. Get all of your plumbing parts together before beginning installation. Installation typically takes 3 to 5 hours. However after installation the Catalox Filter must be allowed to run through a complete backwash and rinse cycle.
5. After the system is installed and running, your water may be discolored, or full of sediment or rust, particularly if this is older or corroded piping. Typically this clears up over a day or two.

Best Practices for Piping & Drain Installation

1. See typical installation (see Fig 2). The Catalox filter is installed after the pressure tank. If you are also installing a water softener, install the softener after the Catalox filter.
2. Make sure to follow to connect the in pipe to the Fleck 2510-SXT inlet and the outlet to the outlet (see Fig 2). As you face the Fleck 2510-SXT control from the front, the water enters on the right and exits on the left. From the back (see Fig 2) the water enters on the left. The inlet and outlet are attached to the bypass valve which is marked with arrows as well.
3. Make sure there is a working gate or ball valve before the Fleck 2510-SXT Catalox filter and also one after as shown in the diagram Fig 2. The pressure gauges are optional and perhaps not necessary but a hose bib (which is a faucet that you can attach a garden hose to) is strongly recommended after the Catalox filter before the second ball valve. This makes it easy to rinse your new Catalox filter on start-up and gives you a place to test the water before it enters your household plumbing.
4. If you will be using copper piping, do not sweat the copper pipe directly on to the Fleck 2510-SXT control valve. Avoid heating up the Fleck 2510-SXT control valve plastic with the torch.
5. You do not need unions to install your Fleck 2510-SXT control. If you need to remove it, the Fleck 2510-SXT has quick-release couplings that make it easy to put the Catalox Catalox filter on by-pass and remove the filter system from the piping.

- The drain line tubing (not supplied) is connected to a drain from the drain outlet using flexible ½" ID tubing. Note that the drain can run up above the Fleck 2510-SXT control and into a drain, it does not have to drain down, as the filter backwashes under line pressure from your well pump. Most plumbing codes require an air-gap connection, so that if your sewer or septic tank backs up, it cannot cross connect with the drain tubing.

How Your Catalox Works

See Fig 1. In your Catalox the water enters the top of the tank (red arrows) and flows down through the media and up the distributor tube (blue arrows). Iron and manganese in the water turns to an oxidized particle upon contact with the media and is trapped in the media. During backwash, the water flow is reversed and water flows down the distributor tube and up through the media, lifting and expanding the Catalox (MANG-OX , also called 'Filox') media, and removing all the iron and rust trapped in the filter. During the backwash the Catalox is cleaned by the action of the water flowing through it.

Fig 1 - Catalox Catalox Filter Tank Water Flow

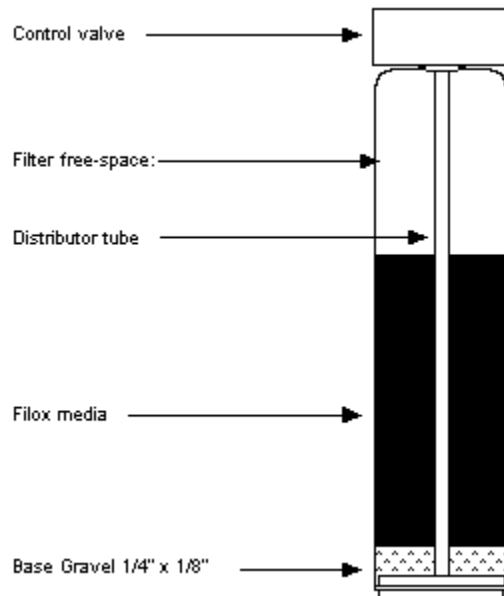
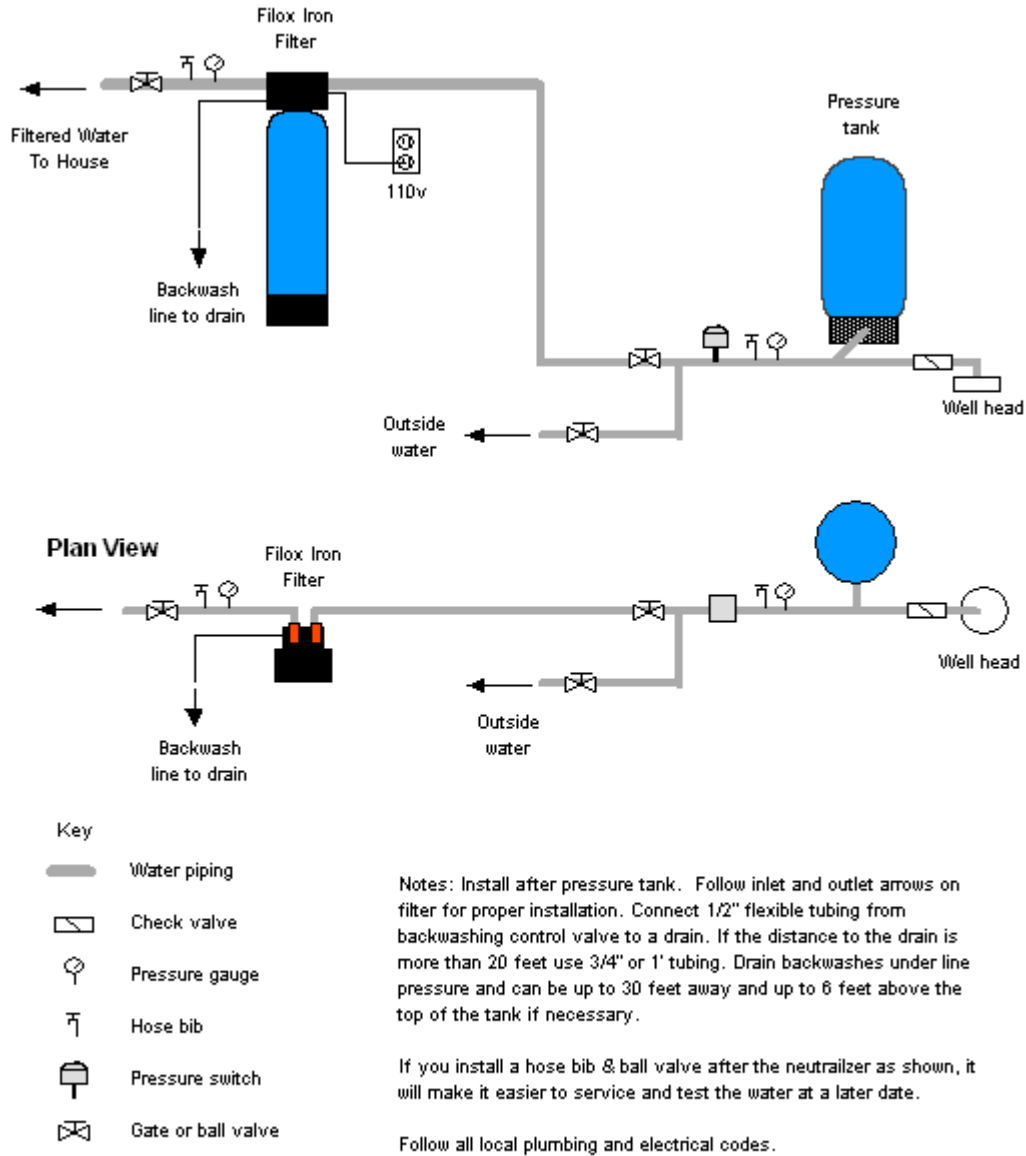

Fig 2 - Typical Catalog Fleck 2510-SXT piping installation with ball valve and hose bib after the filter



Assembly and Installation Instructions

1. Unscrew by hand the entire Fleck 2510-SXT control valve from top of tank if it was shipped screwed on. Place distributor tube in tank if not already inside tank. If not already done, make sure blue cap is on top of distributor tube, or wrap the top of distributor tube with electrical or duct tape. You do not want gravel or Catalox to go down the distributor tube.

Plug or tape top of distributor tube to prevent media from entering distributor tube when adding media. Remove when finished.

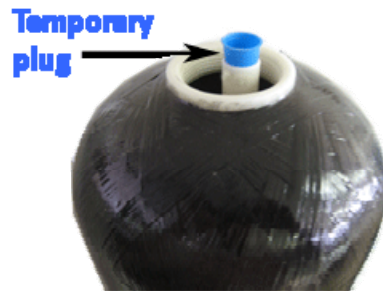

2. Add filter gravel supplied first, using the funnel sent with the Catalox filter. **NOTE: Be sure not to let any parts of the bag or other foreign materials enter the tank when you are adding media.**
3. Next add Catalox (MANG-OX media). Tank will be approximately 60% full.
4. Remove cap or tape from top of distributor tube.
5. If possible at this point, fill tank completely with water. This will allow the Catalox media to settle and eliminate the need of “purging” the air out of the tank later.
6. Attach plastic top screen to the under-side of the Fleck 2510 control valve. It is a funnel-shaped plastic screen that snaps on to the control valve and prevents resin from being backwashed out to drain during the regeneration cycles.
7. Add a small amount of silicone grease or vegetable cooking oil to the Fleck 2510 control valve threads and screw control valve carefully onto the softener tank, making sure not to cross-thread. Do not use pipe-joint compound, Teflon tape, or Vaseline or other petroleum greases to lubricate tank threads. Please Note: When installing Fleck 2510 backwash control-timer valve on to the top of the filter tank, do not over-tighten. Tighten with hands, there is no need for a pipe wrench or other wrench. The control valve is sealed with the o-ring on the base of the control valve. Once you hand-tighten it so the o-ring has sealed against the top of the tank, continue to tighten for perhaps another 1/4 turn until tight. If the control valve is over-tightened and leaks, the black Slip Ring (see control valve manual, it is #26, part 19197 in the exploded view of the control valve) will need to be replaced.

8. See how the Fleck by-pass is connected. Make sure the by-pass valve is in the bypass position when starting the installation. Follow the IN and OUT arrows on the bypass valve and control valve for proper connection of in and out water piping. Leave in the BY-PASS position for now.
9. Now install your water pipes to the Fleck 2510-SXT bypass end connectors. Make sure inlet is installed to the 'In' pipe connector on the bypass valve and outlet is on the "Out" connector.
10. Connect some flexible tubing from the drain connection on the Fleck 2510-SXT control valve to a suitable drain such as a septic tank or drain to a sewer. It is OK to run the drain line up and over the Fleck 2510-SXT Catalox filter up to 4 feet above the top of the tank. If the drain line will be more than 20 feet, use larger diameter tubing such as $\frac{3}{4}$ " or 1". Note that it is desirable to be able to run the drain line into a bucket in order to test the backwash flow rate in the future. This is why hard piping the drain line is discouraged, however, if you do use hard PVC piping for the drain line, and you are able to remove the hard PVC drain piping and attach flexible tubing should you ever desire for testing purposes, it is OK to use rigid PVC pipe for the drain. Make sure the drain tubing is firmly clamped to the barbed fitting with a hose clamp to prevent leaks.
11. **For the 2.5 cubic foot systems only: these larger tank systems have an external stainless steel flow control that comes with the system.** This must be installed. If you have a 1.0 or 1.5 cubic foot system, the flow control is internal and there is no external drain flow control.
12. Plug in your Fleck 2510-SXT control valve to an outlet.
13. Enter Master Programming by following these steps: Set the Time Of Day display to 12:01 P.M. Press the Extra Cycle button (to exit Setting Time of Day mode). Then press and hold the Up and Down buttons together until the programming icon replaces the service icon and the Display Format screen appears.
14. First item that displays should read: DF GAL (this stands for US gallons format, if it is different change by using the up or down arrow)
15. Press the extra cycle button one time.
16. 2nd item that displays should read: "St2b". If it is different, use the up or down arrow to reset to dF which is the correct setting.
17. Press the extra cycle button one time.
18. 3rd item that displays should read: 'tc" (stands for time-clock delayed regeneration)
19. Press the extra cycle button one time.
20. Next item that displays is Unit Capacity. This is not used for the greensand filters and can be skipped. Press Extra Cycle button one time.

21. The 5th item that displays is the frequency of the regeneration each week and should say A – 7 for every 7 days. If you are having some problems with iron bleed-through after the filter has been online for a few days you may want to change it to A - 4. 13.
22. Press the extra cycle button one time. Next item should display: 1 – 10, which refers to 10 minutes of backwash. If your water is extremely high in iron you can change this setting to 12 or 14 minutes to allow some extra backwash time.
23. Press the extra cycle button one time. This is the cycle where solution is sucked in from the POT PERM Solution tank, and if bleach is in the tank, will chlorinate and clean the Catalox Mang-OX media with chlorine bleach. This cycle is 60 minutes long and should display: 2 – 60.
24. Press the extra cycle button one time. This cycle is a second backwash and will clean the media of any residual chlorine. This cycle should display: 3 – 5.
25. Press the extra cycle button one time. This is a rapid rinse and should display: 4 – 8.
26. Press the extra cycle button one time. This should display: 5 -12. This final cycle adds water to the POT PERM solution tank.
27. Press the extra cycle button one time. It will read: LF60 This refers to 60 hz electrical power which is we have in the U.S. If you are in a different country and use 50hz you can change it here.
28. Press the extra cycle button one time to return to the time of day and in-service position.
29. Now press the Extra Cycle button once more.
30. Set the current time of day: Press and hold either the Up or Down buttons until the programming icon replaces the service icon and the parameter display reads T0. Set the current time of day by pressing the up or down arrows until it is the current time of day. When the desired time is set, press the Extra Cycle button to resume normal operation, or wait 5 seconds and the unit will return to normal operation if no button is pressed.
31. You are done programming!
32. Connect the solution from the POT-PERM tank to the 2510 control valve. Remove the felt polypro pad in the POT-PERM tank (needed if you were you using permanganate powder) and add 1 quart of non-perfumed household bleach to the POT-PERM tank and add 2 gallons of water.

Potassium permanganate safety-float assembly

NOTE: remove white poly felt pad when using bleach!



33. Turn on the water and leave the Fleck 2510 control on bypass and check for leaks. Leave the ball valve after the Catalox filter closed, so water is still off to the house, but connect a garden hose and open up the hose bib after the Catalox filter and allow the water to run for several minutes. This important step clears out any foreign material that may be in the pipes from the piping installation. If you do not have a valve installed after the Catalox filter and you do not have a hose bib, you will need to turn the water on inside the house to let the water run. Use a bathtub or laundry sink or other fixture that does not have an aerator screen.
34. Press the Extra Cycle button for a second or two which will start a manual backwash.
35. Now you can slowly turn the bypass valve to the service position and water will start to flow to drain.

36. There should be no Catalox media coming out of the drain line, but the water will be black or dirty looking. At this point the Catalox filter will be in a backwash cycle. The backwash takes 10 minutes. If the water slows down or stops during the first 10 minutes of backwash, press the Extra Cycle to move the Fleck 2510-SXT control to the next cycle, the Rinse cycle. Then repeat the backwash and rinse after the rinse cycle is done, by pressing the Extra Cycle again. If you have high water pressure you may need to turn on the water slowly to the Catalox filter at first to prevent some Catalox fines from coming out the backwash. However it is normal for some small amount of fines to come out during the backwash, although you do not want to see a large amount of media coming out, which would mean you have very high water pressure, or the drain flow for the Fleck 2510-SXT is missing.
37. If possible verify that the backwash flow is 7 gallons per minute for 1.0 cubic foot model, 8 to 10 gallons per minute for the 1.5 cubic foot model, and 15 gallons per minute for the 2.5 cubic foot model. You can easily run the drain hose to a bucket and using a watch verify the flow rate in gallons per minute. An adequate backwash is critical to properly clean the Catalox media and prevent it from cementing together.
38. After the backwash cycle is complete, the 2510-SXT control enters the brine cycle, where it will draw in the chlorine bleach solution from the solution tank. This cycle takes 60 minutes.
39. The next cycle is the 2nd backwash cycle, then the rinse cycle, and finally it refills the solution tank as the last cycle.
40. After the Catalox filter has gone through a regeneration cycle, it may be necessary to repeat the above procedure once or two more times before the media is completely cleaned out.
41. Refer to your Fleck 2510-SXT service manual for more information about how your control valve is programmed.

Maintaining Your Catalox Filter System

Once a week, or at least once a month, add 2 cups of household bleach to the auxiliary chlorine (POT PERM) tank. Never mix permanganate and chlorine bleach together or use permanganate, if you are also using bleach.

Other than add bleach, there is little or no maintenance required. Every 5 – 10 years the Catalox media can be replaced for best results.

If your water has a lot of hydrogen sulfide odor or iron and manganese levels over 10 ppm, a chlorine feed pump may be needed to inject a small amount of chlorine before the well pressure tank and Catalox filter. In most cases this is not necessary but chlorination (or ozone, or peroxide injection) before the Catalox filter can greatly enhance the ability of the media to remove iron, manganese and hydrogen sulfide.

Troubleshooting the Fleck 2510-SXT Catalox Filter

One problem that may occur is if you do not have enough backwash flow rate to properly clean the Catalox filter. You can verify the backwash flow rate by running the drain line into a bucket and timing it when the Fleck 2510-SXT is in Cycle 1 or backwash.

In some cases, the Fleck 2510-SXT may not be programmed correctly. See the Fleck 2510-SXT service manual for instructions on how to access the master programming. Your Fleck 2510-SXT should be set for FLtr or Filter mode and have two cycles, backwash and rinse.

If you are still getting some iron through the system, you can adjust the filter to backwash every 1 or 2 days. In some cases if the untreated water is high in hydrogen sulfide, or the iron level is over 5 ppm, a chlorinator system may be needed before the iron filter, in order for the Catalox media to work properly.