



## 7500-Rev4 Neutralizer Installation & Start-Up Guide

Thank you for purchasing a Clean Water System!

With proper installation and a little routine maintenance your system will be providing neutral pH water for many years.

Please review this start-up guide entirely before beginning to install your system, and follow the steps outlined for best results.

CALCITE MEDIA CONTAINS DUST.

USE PAPER MASK AND VENTILATE TO AVOID BREATHING DUST.

INSTALL INDOORS. NOT FOR OUTDOOR USE. PROTECT FROM WEATHER.



### Questions?

Call us toll-free: 1-888-600-5426 or 1-831-462-8500

Email us: [support@cleanwaterstore.com](mailto:support@cleanwaterstore.com)

See more information on our website: [www.cleanwaterstore.com/resources](http://www.cleanwaterstore.com/resources)

## Table of Contents

Packing List .....	3
What to Do if Your Tank is Not Level .....	3
Pre-Installation .....	4
Best Practices for Piping & Drain Installation.....	4
How the Bypass Valve Works .....	5
Installation of Your System with Copper or Metal Piping Systems.....	5
How Your Neutralizer Works.....	6
Diagram - Typical Neutralizer 7500-Rev4 piping installation on well water .....	6
Tank Assembly and Installation Instructions.....	7
Programming Your Valve and Setting Time and Days for Backwash .....	9
Set the Current Time of Day.....	10
Set the Date.....	10
Performing the Initial Backwash .....	11
Advanced Programming Mode .....	12
Advanced Programming Recommended Settings.....	13
Maintaining Your Neutralizer .....	14
How to Add Calcite Media.....	14
When to Use Calcite Blends .....	15
How to Mix and Use Calcite Blends.....	15
When to Use Calcite Blends .....	16
How to Mix and Use Calcite Blends.....	16
How much Calcite and Flomag (Corosex) Weighs Per Cubic Foot .....	17
pH is Too High.....	18
pH is Too Low .....	18
White Spots on Fixtures and Glasses .....	19
7500-Rev4-Rev4 Water Filters Limited Warranty .....	20

## Packing List

### All systems include:

7500-REV4 control valve, bypass valve, small tube of silicone grease, power supply, funnel for adding media the first time, top screen, start-up guide, and items included in one of the following options:

#### Neutralizer Filter 1.0 cubic foot size

10" x 44" filter tank with distributor tube  
12 lbs. Filter gravel  
2 50 pound bags of Purical Calcite

#### Neutralizer Filter 1.0 cubic foot size (Short Tank)

13" x 30" filter tank with distributor tube  
12 lbs. Filter gravel  
2 50 pound bags of Purical Calcite

#### Neutralizer Filter 1.5 cubic foot size

10" x 54" filter tank with distributor tube  
16 lbs. Filter gravel  
3 50 pound bags of Purical Calcite

#### Neutralizer Filter 2.0 cubic foot size

12" x 48" filter tank with distributor tube  
20 lbs. filter gravel  
4 50 pound bags of Purical Calcite

#### Neutralizer Filter 2.5 cubic foot size

13" x 54" filter tank with distributor tube  
35 lbs. filter gravel  
5 50 pound bags of Purical Calcite

## What to Do if Your Tank is Not Level

Your black filter tank base is not glued to the bottom of your tank. Occasionally tank bases will become crooked during shipment. If you find that that your tank does not sit level on the floor, you can easily adjust it by holding the empty tank and gently knocking the base on a concrete or solid floor once or twice to level it.

## Pre-Installation

1. Review your packing list and make sure you have received all the parts before installation.
2. If you are going to be turning off the water to the house and you have an electric water heater, shut off the power to the water heater before beginning installation in case water heater is accidentally drained.
3. Pick a suitable location for your filter system on a dry level spot where it won't be exposed to freezing temperatures. A minimum of 20 PSI is required. Maximum pressure is 90 PSI.
4. Get all of your plumbing parts together before beginning installation, and make sure you have received all of your packages before beginning or scheduling an installation. Installation typically takes 3 to 5 hours. However, after installation the neutralizer filter must be allowed to run through a complete backwash and rinse cycle.

## Best Practices for Piping & Drain Installation

1. Make sure to connect Inlet **from** your water source and outlet, following arrows on control valve.
2. Make sure there is a working gate or ball valve before the system and also one after as well as a bypass valve.
3. A hose bib (which is a faucet to which you can attach a garden hose) is **strongly recommended** after your filter system and before the second ball valve. This makes it easy to rinse your filter system on start-up and gives you a place to test the water.
4. If you will be using copper piping, do not sweat the copper pipe directly on to the 7500-REV4 control valve.
5. To connect drain line to drain, use an air-gap connection, so that if your sewer or septic tank backs up, it cannot cross connect with the drain tubing.
6. The pipe connectors are 1" male pipe thread but you can add a reducer to reduce to ¾" pipe with common pipe fittings if needed.
7. Make sure bypass valves are closed (system is in bypass) when you first start installing and keep on bypass until you are ready to start it up with the first backwash.



### How the Bypass Valve Works

Turn knob so the valve is bypassed when installing.

After start up move the valve to in normal service.



### Installation of Your System with Copper or Metal Piping Systems

If your new neutralizer is to be installed in a metal plumbing system such as copper or galvanized steel pipe, the plastic components of the system will interrupt the electrical continuity of the plumbing system.

Some homes may have been built in accordance with building codes, which encouraged the grounding of electrical appliances through the plumbing system.

Consequently, the installation of a bypass consisting of the same material as the existing plumbing, or a grounded "jumper wire" bridging the equipment and reestablishing the contiguous conductive nature of the plumbing system must be installed prior to your systems use. Wire clamps and wire can be purchased at any home depot or hardware store.

If you have copper pipe before the Neutralizer and it is too difficult to change out, you may still experience some copper staining of fixtures and have a copper residual in the water because this section of pipe will still have acidic water flowing through it. We recommend PEX or PVC pipe up to the Neutralizer and then copper after it, if you have copper plumbing.

## How Your Neutralizer Works

In your Neutralizer, the water enters the top of the tank and flows down through the media and up the distributor tube and out to the home plumbing.

The calcite neutralizer media raises the pH of your water as the water flows through it.

Periodically (once or twice a week) the neutralizer automatically backwashes which cleans and re-classifies the Calcite, preventing channeling.

During backwash the flow of water is reversed and water flows down the distributor tube and up through the media, lifting and expanding the Calcite media.

During the backwash the Calcite is cleaned by the action of the water flowing through it.



## Diagram - Typical Neutralizer 7500-Rev4 piping installation on well water

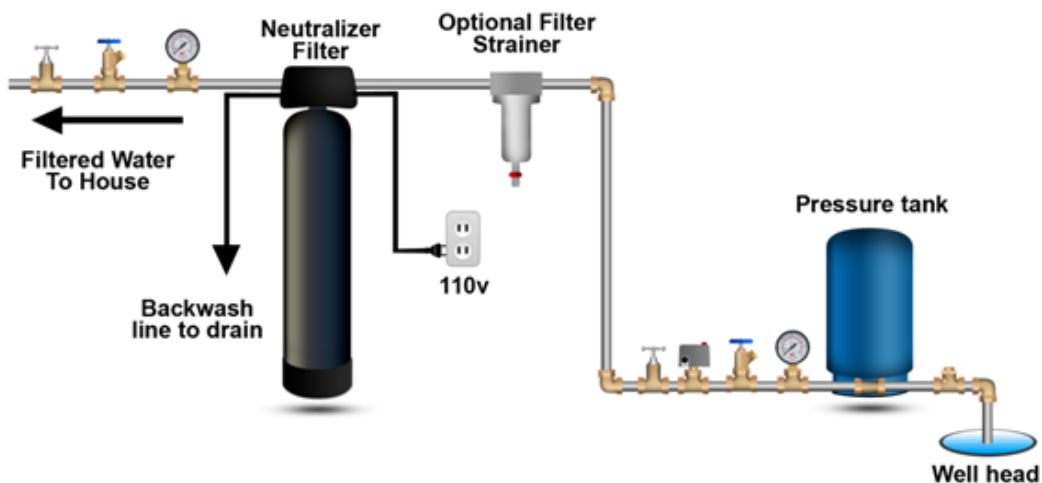

# 7500-Rev4 Neutralizer Installation & Startup Guide

## Tank Assembly and Installation Instructions

1. Wrap the top of distributor tube with electrical or duct tape so that no gravel or Calcite media will go down the distributor tube when adding the media.
2. Add the filter gravel that came with your order. You want the gravel to cover the bottom distributor screen before adding the Calcite media.
3. Next add Calcite media. The tank should be about 2/3rds full of media, **do not fill more than 2/3rds, even if there is some calcite media left over.**
4. Remove cap or tape from top of distributor tube. Be careful not to pull up distributor tube when removing cap or tape.
5. **Fill tank completely with water.** This will allow the neutralizer calcite media to settle and reduce the need of purging the air out of the tank later.
6. Add a small amount of silicone grease to the inner O-ring, where the distribution tube goes.
7. Next, install the top screen by inserting upwards and rotating to lock in place. (This is a funnel-shaped plastic screen that locks into the bottom side of control valve.
8. Lubricate the main tank O-ring with silicone grease and screw on the 7500-Rev4-Rev4 control valve carefully. Do not use pipe-joint compound, vegetable oil, Teflon tape, or Vaseline or other greases to lubricate tank threads.
9. Connect bypass assembly with 1" pipe connectors to control valve.
10. Insert meter cable into meter cable port on bypass

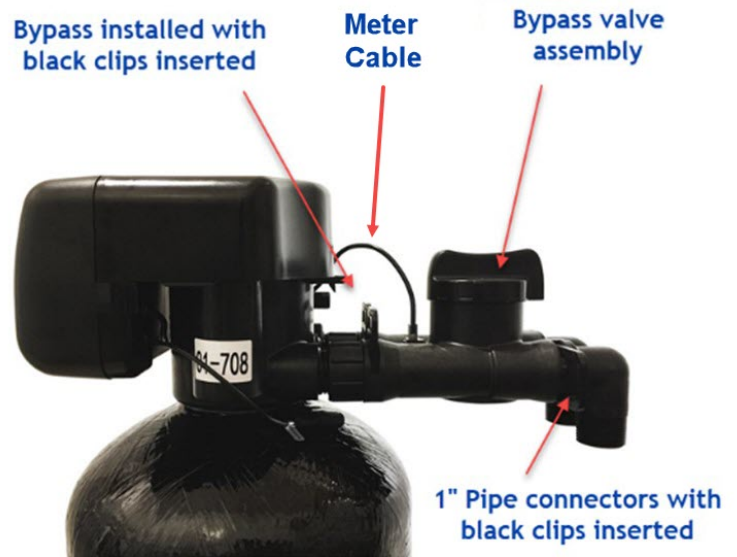

## 7500-Rev4 Neutralizer Installation & Startup Guide

11. Install inlet and outlet piping and hook up drain line tubing to drain.
12. If you are in earthquake zone, strap your backwash filter tank to wall with metal strapping.
13. Proceed to programming your 7500-Rev4-Rev4 control valve timer and backwash frequency.
14. **IMPORTANT: you must program the time and then start a backwash and rinse. The filter system must be backwashed and rinsed several times before using. See following pages for instructions.**

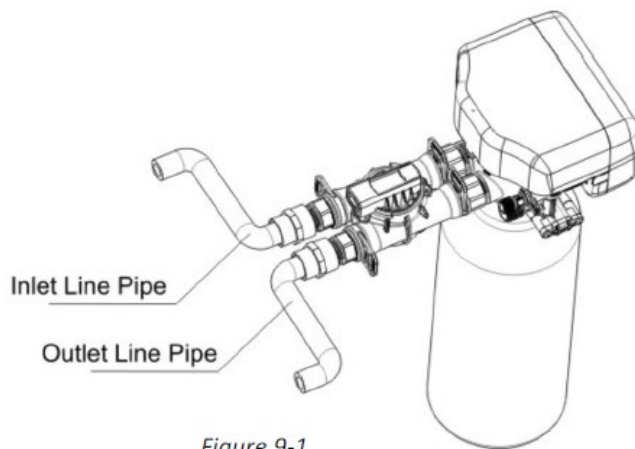
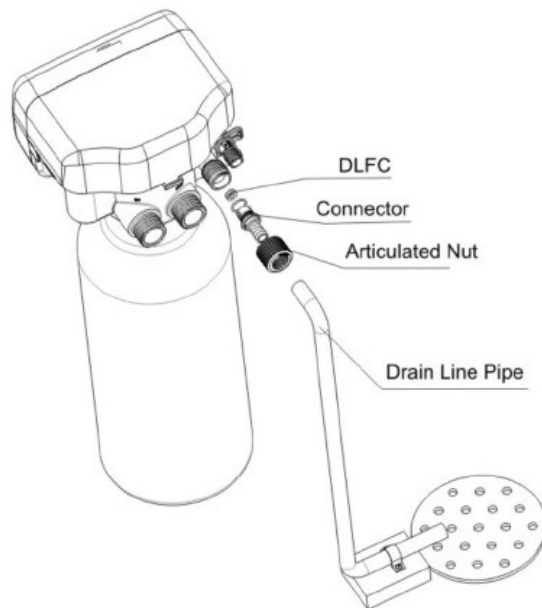

Figure 9-1





## Programming Your Valve and Setting Time and Days for Backwash



### How to Start a Manual Backwash: Press the Back / Regen button

Pressing “**Back Regen**” at any time results in an immediate manual regeneration.

Pressing and holding for 3 seconds, when system is locked, results in a delayed regeneration at the preselected time.

### Extended Power Outage Indicator

If power outage exceeds 3 days, the time-of-day indicator “\_” will flash 12:12. The current time of day needs to be re-set. All other set parameters remain stored in memory. The valve will resume to operate from the point of the power outage.

### Lockout Function

Keypad will lock after 5 minutes without use. To access the parameter changes, press and hold “**Up**” and “**Down**” buttons simultaneously for 3 seconds to unlock.

**NOTE: To start all you need to do is set current time and date. All other parameters have been preset for you.**

# 7500-Rev4 Neutralizer Installation & Startup Guide

## Set the Current Time of Day

1. If LOCK icon is lit, press, and hold both **UP** and **DOWN** buttons for 3 seconds to unlock keypad.
2. Then press the **MENU/CONFIRM** button to enter the main menu.
3. Press DOWN button to select "Set Time of Day"
4. Press the **MENU/CONFIRM** button again to change time of day (Hour will flash)
5. Adjust hour by using DOWN or UP buttons.
6. Press the **MENU/CONFIRM** button again to change minutes (Minutes will flash)
7. Adjust minutes by using DOWN or UP buttons.
8. Press Back/Regen



## Set the Date

1. If LOCK icon is lit, press, and hold both **UP** and **DOWN** buttons for 3 seconds to unlock keypad.
2. Then press the **MENU/CONFIRM** button to enter the main menu.
3. Press DOWN button to select "Set Date"
4. Month: Press the **MENU/CONFIRM** button again to change time of day (Month will flash) and adjust to current Month date by using DOWN or UP buttons.
5. Day: Press the **MENU/CONFIRM** button again to change Day date (Day date will flash) and adjust to current day date by using DOWN or UP buttons.
6. Year: Press the **MENU/CONFIRM** button again to change Year date (Year date will flash) and adjust to current Year by using DOWN or UP buttons.
7. Press **BACK/REGEN** button to save current date and go back to menu.

**Continue to use this same procedure for changing remaining settings.**

**Set Service Days** This is the number of days between backwash. Set for every 7 days.

**Set Regen Time** This is the time your system will backwash. Default is 2:00 AM

---

## 7500-Rev4 Neutralizer Installation & Startup Guide

---

**Set Backwash Time** Set for 10 minutes.

**Set B.S.R. Time** Not used. Keep or change to 0 minutes.

**Set Fast Rinse Time** Set for 8 minutes.

**Set B.R. Time** Not used. Keep or change to 0 minutes.

**Review Regen Times** This is number of times the system has backwashed. Just for reviewing.

**Review Software Version** Version 5.0

### Performing the Initial Backwash

- 1 **After programming, the system must be run through 2 or 3 backwash/rinse regeneration cycles to clean the new filter media.**
- 2 Start with both bypass valves in the Bypass Position.
- 3 Press the **BACK/REGEN** button once to enter the backwashing cycle.
- 4 When the backwash icon is displayed, slowly open the bypass to a quarter position to make the water flow into the tank. Allow to fill slowly.
- 5 After all the air is out of the pipeline, open bypass valve completely and complete backwash.
- 6 If possible, verify that the backwash flow corresponds with the size of your system below. You can easily run the drain hose to a bucket and using a watch verify the flow rate in gallons per minute. An adequate backwash is critical to properly clean the calcite media.

Make sure you have a minimum of these flow rates. For example, if the backwash water fills a 5-gallon bucket in 1 minute, you have 5 gallons per minute (GPM).

<b>1.0 CF</b>	5 GPM
<b>1.5 CF</b>	6 GPM
<b>2.0 CF</b>	8 GPM
<b>2.5 CF</b>	10 GPM

---

## 7500-Rev4 Neutralizer Installation & Startup Guide

---

- 7 After the backwash, the system will automatically go into the fast rinse stage. The control valve will return to service status (indicated by the up flowing meter on the left) after the backwash and rinse are complete.
- 8 Repeat the Regeneration (backwash and rapid rinse cycle) step 2 to 3 more times until you see clear water through the drain line or your hose bib.

**Congratulations, you are done setting up your valve!**

### Advanced Programming Mode

Can be skipped. The Advanced Programming Mode allows you to set the Regen Cycle and Regen Mode. Skip this for most applications as your filter system has already been set to correct mode.

1. Plug the RevV4 in and immediately press in sequence **MENU/CONFIRM** then press **BACK/REGEN** button then press the **DOWN** button in sequence to enter the Advanced Programming Mode.
2. Press **UP** or **DOWN** buttons or to select the menu item to be changed (Press **MENU/CONFIRM** to return to the previous menu).
3. Note: If valve locks while programming, unplug power supply and repeat step above.
4. Press **MENU/CONFIRM** to enter the main menu
5. Press the **UP** or **DOWN** buttons to highlight each option.
6. Press **MENU/CONFIRM** to enter highlighted option.
7. Press the **UP** or **DOWN** buttons to adjust the value.
8. Press the **MENU/CONFIRM** to accept the changes.
9. Press **BACK/REGEN** button to advance to service status

## Advanced Programming Recommended Settings

<b>Review Company Info</b>	NA
<b>Set Valve Model</b>	62605
<b>Set Language</b>	English
<b>Set Company Info</b>	CWS 831-462-8500
<b>Set Hour Mode</b>	12 HR
<b>Set Time of Day</b>	Current time of day
<b>Set Date</b>	Current date
<b>Set Program Type</b>	Interlock
<b>Set Regen Cycles</b>	<b>No. 1</b>
<b>Set Set Clear Data</b>	Close
<b>Set Regen Mode</b>	<b>A-06</b>
<b>Set Service Days</b>	7
<b>Set Regen Time</b>	2:00 AM
<b>Set Backwash Time</b>	10 Minutes
<b>Set B.S.R. Time</b>	0
<b>Set Fast Rinse Time</b>	8 Minutes
<b>Set B.R. Time</b>	0
<b>Signal Output Mode</b>	b-01
<b>Set Service Alarm</b>	Disabled
<b>Review Regen Times</b>	NA
<b>Review Software Version</b>	Ver. 5.0

### Maintaining Your Neutralizer

1. Check the pH before and after the neutralizer. You want to have a pH of at least 7.0 after the neutralizer filter.
2. If the pH drops below 7, check the depth of the Calcite media by shining a bright light through the tank. Your tank should be about 2/3rds full of media. When the media level drops to ½ full, it is time to add more Calcite or Calcite blend media .
3. **For most residential applications, adding Calcite media once or twice a year is adequate. Do not fill more than 2/3rds full.**

### How to Add Calcite Media

CALCITE MEDIA CONTAINS DUST. USE PAPER MASK OR VENTILATE TO AVOID BREATHING DUST.

1. Begin by putting the neutralizer filter on bypass or turning the water pressure off.
2. Initiate a manual backwash cycle. Since it is on bypass, this will relieve the pressure inside the control valve, so you safely unscrew the Media Fill Plug located on top.
3. Unplug the control valve cord from the wall outlet.
4. Unscrew the media fill plug with channel locks or pliers and using a tube or hose siphon 2 to 3 gallons of water out of the filter tank. If you don't siphon water out before adding filter media, water will flow out the fill plug hole and onto the floor.
5. Add neutralizer filter media until the tank is 2/3rds full. Do not over-fill; be sure to leave at least 12" of free space above the media to allow room for it to expand during a backwash.
6. Put the top fill plug back in. Do not use Teflon tape or plumbing grease, it is an O-ring seal.
7. Plug the control valve back in. The control valve is in the backwash cycle.
8. Turn on the bypass valve - slowly at first - back to full open.
9. Allow the system to go through a complete backwash and rinse cycle. Repeat this backwash and rinse cycle by starting another manual cycle, so the neutralizer is thoroughly backwashed and rinsed before going back into service.

### When to Use Calcite Blends

If the water pH is less than 6.0, Calcite alone may not be enough to bring the pH up to the desired range of 7.0 to 7.8. In this case, a blend of Calcite and Magnesium Oxide (sold as Corosex or FloMag brand). should be used.

Calcite is a calcium media consisting of calcium Calciteate and will raise the pH slowly. Calcite will not raise the pH much over 7.2.

Corosex/FloMag is a natural mineral media consisting of magnesium oxide. It reacts much faster and raises the pH much higher than Calcite alone.

Corosex is almost never used alone as it will raise the pH too high and, in some cases, will over- correct and create a highly basic (high pH) condition. It can also cement together like concrete in the neutralizer tank if you add too much and there is not sufficient backwash.

For most residential well applications, a 90% Calcite and 10% Corosex is best.

However, in some cases an 80%/20% mix or even a 70%/30% is used. It is always better to start with a 90%/10% mix at first as this solves most of low pH problems in the range of 4.5 to 5.9.

**For a pH of 5.0 to 6.0 use a blend of Calcite and Corosex usually 90% Calcite and 10% Corosex, or more Corosex as needed if the pH is less than 5.0.**

### How to Mix and Use Calcite Blends

The Calcite and Corosex media are sold and shipped in separate boxes. It does not have to be completely blended to use as it will mix during the backwash and rinse cycles.

When you are adding the Calcite and Corosex it is better to blend it lightly in a 5-gallon bucket and then add it.

You can also add some Calcite and then add some Corosex as you are filling the tank.

**WARNING:** If you are using a Calcite Blend, do not add all the media that was shipped with your order. This will result in the tank being more than 2/3 full and can cause media to get back up into the control valve during backwashing. This can then result in damage to the control head. If the tank is overfilled, use a shop vacuum to remove media back to the 2/3 fill line

### When to Use Calcite Blends

If the water pH is less than 6.0, Calcite alone may not be enough to bring the pH up to the desired range of 7.0 to 7.8. In this case, a blend of Calcite and Magnesium Oxide (sold as Corosex or FloMag brand). should be used.

Calcite is a calcium media consisting of calcium Calciteate and will raise the pH slowly. Calcite will not raise the pH much over 7.2.

Corosex/FloMag is a natural mineral media consisting of magnesium oxide. It reacts much faster and raises the pH much higher than Calcite alone.

Corosex is almost never used alone as it will raise the pH too high and, in some cases, will over- correct and create a highly basic (high pH) condition. It can also cement together like concrete in the neutralizer tank if you add too much and there is not sufficient backwash.

For most residential well applications, a 90% Calcite and 10% Corosex is best.

However, in some cases an 80%/20% mix or even a 70%/30% is used. It is always better to start with a 90%/10% mix at first as this solves most of low pH problems in the range of 4.5 to 5.9.

**For a pH of 5.0 to 6.0 use a blend of Calcite and Corosex usually 90% Calcite and 10% Corosex, or more Corosex as needed if the pH is less than 5.0.**

### How to Mix and Use Calcite Blends

The Calcite and Corosex media are sold and shipped in separate boxes. It does not have to be completely blended to use as it will mix during the backwash and rinse cycles.

When you are adding the Calcite and Corosex it is better to blend it lightly in a 5-gallon bucket and then add it.

You can also add some Calcite and then add some Corosex as you are filling the tank.

**WARNING:** If you are using a Calcite Blend, do not add all the media that was shipped with your order. This will result in the tank being more that 2/3 full and can cause media to get back up into the control valve during backwashing. This can then result it damage to the control head. If the tank is overfilled, use a shop vacuum to remove media back to the 2/3 fill line



### How much Calcite and Flomag (Corosex) Weighs Per Cubic Foot

- Calcite is shipped in 50 lb. boxes and one box of Calcite is equal to 0.55 cu ft.
- Corosex is shipped in 10 lb. boxes and 1 box is equal to 0.13 cu ft.

**Neutralizers 1.0 Cubic Foot:** use 90 lbs. Calcite and 10 lbs. Corosex Your new 1.0 Cubic Foot Neutralizer Blend filter order includes:

- Calcite 100 lbs. (2 50-lb. boxes) 1.1 cu ft.
- Corosex 10 lbs. (1 10 lb. boxes) .13 cu ft.

**Neutralizers 1.5 Cubic Foot:** use 150 lbs. Calcite and 10 lbs. Corosex Your new 1.5 Cubic Foot Neutralizer Blend filter order includes:

- Calcite 150 lbs. (3 50-lb. boxes) 1.65 cu ft.
- Corosex 10 lbs. (1 10 lb. boxes) .13 cu ft.

**Neutralizers 2.0 Cubic Foot:** use 150 lbs. Calcite and 15 lbs. Corosex Your new 2.0 Cubic foot Neutralizer Blend filter order includes:

- Calcite 150 lbs. (4 50 lb. boxes) 2.2 cu ft.
- Corosex 20 lbs. (1 20 lb. boxes) .26 cu ft.

**Neutralizers 2.5 Cubic Foot:** use 200 lbs. Calcite and 20 lbs. Corosex Your new 2.5 Cubic Foot Neutralizer Blend filter order includes:

- Calcite 200 lbs. (5 50 lb. boxes) 2.75 cu ft.
- Corosex 20 lbs. (2 20 lb. boxes) .26 cu

### pH is Too High

If the pH after your neutralizer is greater than 8.5, your pH kit may turn the color of the reagent, a purple color. This is nothing to be alarmed about.

In some cases, too much Corosex added to the Calcite-Corosex blend can cause this problem; it almost never happens with Calcite only systems.

If this happens, set the backwash cycle frequency to every night for a couple of weeks, which will cause the media to be washed more thoroughly and use up the excess Corosex.

Alternatively, you can manually backwash it several times on a given day, etc. Secondly, you can open the bypass valves slightly, and allow some untreated water to lower the pH by blending in some of the lower pH water.

When you go to add more media in 6 to 12 months, just add less Corosex.

### pH is Too Low

This can happen if the water entering the neutralizer has a pH less than 6.0.

Generally, the water after your neutralizer should have a pH of 7.0, and the pH reagent in your pH test kit should turn a light green to darker green depending on the pH.

Give your neutralizer some time, and after several weeks, if the pH is still coming out less than 7 and the test reagent is yellowish in color, you may need to add some Corosex to the neutralizer. Contact our office if you don't have any Corosex on hand and/or you ordered a Calcite-only system.

The Calcite-only systems work best if your water's pH is between 6 and 6.9 and are desirable as they add fewer minerals to the water, so it is best to start out with a Calcite only system if your pH is 6.0 to 6.9. This works for most our customer.

### White Spots on Fixtures and Glasses

Calcite neutralizers work by adding natural calcium minerals to the water. Many natural well or spring waters that are acidic (with a pH of less than 7.0) are low in minerals and are considered “soft” water.

This lack of natural buffering calcium minerals contributes to the corrosive nature of these waters. After the water has passed through the neutralizer, the water will be higher in calcium and “harder” but typically not hard enough to warrant a water softener, which removes calcium hardness.

It is more common to see some white film or spotting on fixtures if you are using a blend of Calcite and Flomag (also sold under the Brand “Corosex”).

In some cases, it might be that too much Flomag was used originally in the mix of media.

If you are starting to see white spots and films on surfaces after the neutralizer has been installed, you might want to take these steps:

1. Set the backwash frequency for every 3 days for a couple of months.
2. Check the hardness level before and after. If your hardness is higher than 5 grains per gallon after the neutralizer, your neutralizer may be adding more minerals than is needed, and you can open the bypass valves a slight amount to blend in some untreated water.

Check the pH before and after. You only need the pH to be in the 7.0 to 7.5 range. If the pH is higher than that, you may be adding more Corosex than is needed

---

# 7500-Rev4 Neutralizer Installation & Startup Guide

---

## 7500-Rev4-Rev4 Water Filters Limited Warranty

We warrant this water filter when installed according to factory recommendations, to be free from defects in materials and workmanship as follows:

### -----Limited Warranty-----

This water conditioner unit is comprised of the finest industry components available. Each individual component used in the assembly of our equipment is covered by the original equipment manufacturer's warranty. All components, except those specifically listed below, are warranted for a period of one (1) year from date of installation to the original purchaser to be free of defects in materials and workmanship subject to the manufacturer's conditions and/or the conditions shown below.

### -----Mineral Tanks-----

The fiberglass, polyglass or composite mineral tanks used in the assembly of this unit are warranted to be free of defects in materials and workmanship for a period of ten (10) years on 6" – 13" size tanks, and five (5) years on 14" and larger size tanks used for softener/filtration applications, subject to the manufacturer's conditions and/or the conditions shown below.

**Warranty does not cover exposure to weather, freezing, fractures caused by external impact, or exposure to vacuum.**

### -----Control Valves-----

The CWS control valve is warranted to be free of defects in materials and workmanship for a period of five (5) years.

### -----Conditions-----

1. This warranty only covers water conditioners installed for residential use. Water conditioners installed for commercial or industrial applications are guaranteed for one (1) year from the date of installation.
2. Installation must be made in accordance with legal or local codes and manufacturer's recommendations.
3. Failure must not result from exposure to weather, rodents, misuse, alteration, fire, lightning, power surges or neglect.
4. Water pressure must not exceed 100 PSI and water temperature must not exceed 100 degrees.
5. Subject to the above terms and conditions we will replace and/or repair, at our option, any parts of the water conditioner found defective in materials and workmanship. Defective parts must be returned, freight pre-paid for repair or replacement.
6. **This warranty does not cover labor, shipping charges, damages caused by delays of consequential damages or other causes beyond our control. Warranty does not cover pipes, fixtures or appliances. Warranty extends to the actual water conditioner components only.**
7. This warranty is to the original purchaser and is not transferable to any subsequent owner(s).
8. No other guarantees or warranty, expressed or implied, is applicable to our product. No repair or replacement made under the terms of the warranty shall extend this warranty.

Any product returned to Clean Water Store without a valid return authorization number will be rejected. Any product found to be defective will, at the sole discretion of Clean Water Store be repaired or replaced. Clean Water Store is not responsible for shipping cost to the repair facility.