



## Clean Water Made Easy

www.cleanwaterstore.com

### **Congratulations on purchasing your new Ozone 500-i Multifunctional Ozone & Negative Ion Generator! Please read these instructions before operating.**

Features and functions include purifying air and water, cleaning fresh foods, eliminating odors, and killing bacteria. It also works great for improving air quality in schools, hospitals, offices, homes, and businesses.

There is no maintenance required, simply wipe off the unit periodically with a damp cloth. Do not use any chemicals or cleaning agents on the unit itself.

### Installation

1. First, attach the ceramic diffusion stone to the tube by wiggling the tube onto the ceramic stone connection piece. (Photo 1)



2. Next, attach the other end of the tube to the unit by wiggling the tube onto the tube connection piece (located on the right side of the unit, to the left of the "Beware Electric" warning sticker. (Photo 2)
3. Finally, plug the power cord into the power receptacle and then into a wall outlet.



### Start Up

Press the On/Off button.

Then press the "Set" button to use either the Ozone Generator (RED light), or the Negative Ion Generator (GREEN Light). However, you cannot run both at once.

**At this point, the air pump will start up but the unit will be on standby.**

Set the timer to the amount of time desired using the "+" and "-" buttons, and let it run. The unit will start to buzz, and after about a minute or so, you should be able to smell the ozone (do not directly inhale).



# Using The Ozone 500-i

## Using The Ozone Generator

Press the "Set" button until the RED light above "Ozone" is on.

### Ozonating Food:



Place ozone diffuser stone in glass carafe or large bowl, add 1 - 2 gallons of water and fruits or vegetables or meats to be sanitized. Run ozone into container for 5 minutes. Let sit for 10 to 20 minutes, then rinse with disinfected water.

### Ozonating Water:



Fill 1 gallon glass or plastic jug with water and place ozone diffuser stone at the bottom of the jug. Run ozone for 3 minutes. Place lid on jug and let sit for 15 to 30 minutes.

### Ozonating Air:

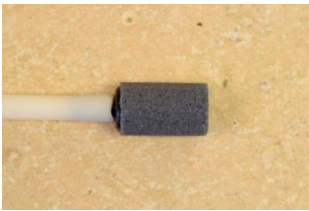

Depending on room size, turn on ozone for 5 to 10 minutes. Do not ozonate when people or pets are present. Allow ozone to sit for 1 to 4 hours and then air room out. Ozone is a great way to kill molds and eliminate odors such as tobacco or musty smells. It is not recommended to breathe ozone gas directly. The stone and tubing should be attached when using the Ozone 500i to ozonate air or water.

**\*See next page for more details on usage and timing**

## Using The Negative Ion Generator

Press the "Set" button until the GREEN light above "Anion" is on. The ions will be emitted out the back, although it will work fine if placed flat on a counter. The Ozone 500-i can sit on a table or other flat surface, or can be wall mounted.



Run for 30 minutes once or twice to clean air of dust, molds, pollens. Makes room air fresh and has positive effect on well-being.

# Top 9 Uses of Ozone in the Home and Office

Use	Benefits	How To Do It
<b>1) Purify &amp; treat water for drinking.</b>	Eliminate bad tastes, odors, chlorine, bacteria, iron, tannins. Dramatically increases level of oxygen in water, making water healthier and much better for drinking.	Put ozone ceramic diffuser stone in 1/2 gallon to one gallon glass or pitcher with lid. Allow ozone to run for 5 to 7 minutes. Close container with lid and allow to sit for 10 minutes before use.
<b>2) Make a powerful disinfectant cleaner. Kill bacteria on surfaces.</b>	Clean counters with ozone water and eliminate bacteria and odors.	Ozonate water for 5 minutes, use immediately to wash down surfaces.
<b>3) Clean meat , fish, poultry, vegetables, and fruits using ozone water.</b>	Wash chicken, meats, fruits and vegetables in ozonated water to destroy pathogens and remove chemical residue.	Immerse food in a glass or stainless steel container. Run ozone generator for 5 minutes. Keep lid on for an additional 5 to 10 minutes.
<b>4) Create your own dental wash to kill bacteria in the mouth.</b>	Ozone has been effectively used to treat oral infection caused by bacteria such as Streptococcus. <small>*Johansson E, Claesson R, van Dijken JW. Antibacterial effect of ozone on cariogenic bacterial species. J Dent. 2009;37:449-5</small>	Ozonate glass of water for 1 minute. Wash mouth for 30—60 seconds and rinse with plain water.
<b>5) Preserve grains and pasta for long term storage.</b>	Kills fungus, molds and worms in grains and other foods. Prolongs life of food for storage.	Place ozone ceramic diffuser in bottom of jar or container with grains for 30 seconds. Cap lid and place in storage.
<b>6) Preserve bottled water for long term storage.</b>	Keeps water fresh by killing bacteria and oxygenating water. Store water for 1—3 years.	Place tap or filtered water in a 5 gallon bottle or other container. Run ozone for 3 to 5 minutes. Cap bottle and store.
<b>7) Extend life of cut flowers</b>	Keeps cut flowers lasting much longer by super oxygenating the water in the vase, killing bacteria and keep flowers alive for longer periods	Put ozone diffuser stone in flower vase with water. Turn on for 1 minute.
<b>8) Eliminate tobacco odors, molds and other airborne contaminants.</b>	Quickly eliminates odors in rooms.	Run ozone generator in a closed room for 2—4 minutes. Do not breathe ozone, keep room closed for 1—2 hours.
<b>9) Ozonate laundry to kill odors in clothing and eliminate need for chlorine bleach, use less detergents.</b>	In the laundry, eliminates need for bleach and makes clothes cleaner and fresher. Wash in cold, and use less detergents.	Fill washing machine with cold water. Place diffuser in water and run ozone for 3 to 4 minutes. Wash clothes as normal, but use less detergents.

## Details

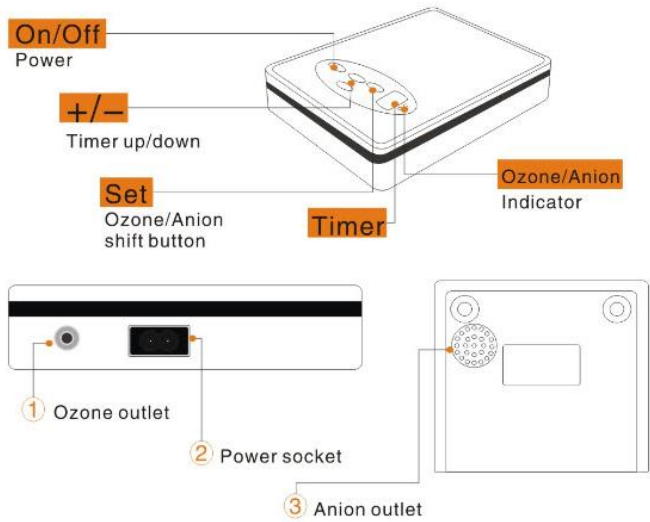

## Circuit layout

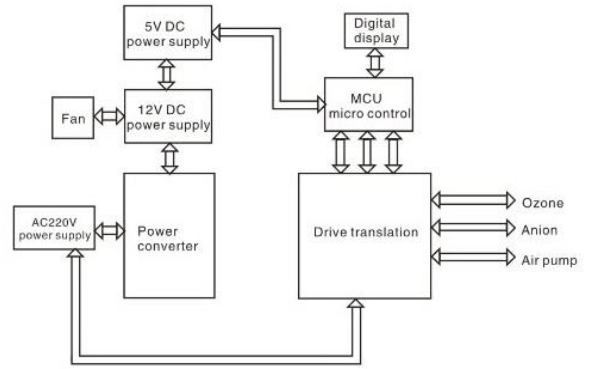

## Specification

Model	Size	Weight	PCS/C M3	Ozone output	Power	Voltage
OZ500-i	6.3" x 2" x 9"	2.2 lbs	300,000	500mg/h	20 W	120V/220v

## Warranty

The Ozone 500-I is warranted against defects in materials and workmanship for a period of 18 months from date of purchase. Liability is limited to parts and labor only. Shipping for returns or repair is the responsibility of the customer. Clean Water Systems assumes no liability for damage caused by shipping, misuse, or neglect.

## Liability

Clean Water Systems assumes no responsibility for any damage to items from the use or misuse of this product. It is the customer's responsibility to test materials prior to use and to ensure the procedure used is appropriate for the application.

## Maintenance

There is no maintenance required, simply wipe off the unit periodically with a damp cloth. Do not use any chemicals or cleaning agents on the unit itself.

## Additional Notes

1. Operate the Ozone 500-I in a dry and cool place. Do not use in very hot weather.
2. Do not open the case, there are no serviceable in the machine.
3. Unplug if the machine is not going to be used for extended periods of time.
4. Keep outer casing clean.

## Questions?

Call us toll-free: 1-888-600-5426 or 1-831-462-8500

Email us: [support@cleanwaterstore.com](mailto:support@cleanwaterstore.com)

See more information on our website: [www.cleanwaterstore.com/resources](http://www.cleanwaterstore.com/resources)