



Clean Water Made Easy

www.cleanwaterstore.com



CWS Plus Greensand Filter Installation & Start-Up Guide

Thank you for purchasing a Clean Water System! With proper installation and a little routine maintenance your system will be providing neutral pH water for many years.

Your new system comes with a printed CWS Service manual, which along with this start-up guide will help guide you in the installation and start-up of your new system. The CWS service manual covers other types of systems as well such as water softeners and filters, so there may be information in your CWS service manual that does not pertain to your system. Please review this start-up guide entirely before beginning to install your system and follow the steps outlined for best results.

GREENSAND MEDIA CONTAINS DUST. USE PAPER MASK AND VENTILATE TO AVOID BREATHING DUST.

Questions?

Call us toll-free: 1-888-600-5426 or 1-831-462-8500

Email us: support@cleanwaterstore.com

See more information on our website: www.cleanwaterstore.com/resources



Clean Water Made Easy

www.cleanwaterstore.com

Table of Contents

Packing List.....	3
Neutralizer 1.0 cubic foot size	3
Greensand Filter 1.5 cubic foot size.....	3
Greensand Filter 2.0 cubic foot size.....	3
Pre-Installation.....	4
Best Practices for Piping & Drain Installation	4
How Your Greensand Filter Works	5
Fig 1 - Greensand Filter Tank Water Flow.....	6
Fig 2 - Typical Plus Greensand Filter piping installation with ball valve and hose bib after filter.....	6
Assembly and Installation Instructions	7
Fig 3 CWS Plus By-Pass and Pipe Connectors.....	10
Troubleshooting the CWS Plus Greensand Filter	14

Packing List

Greensand Filter 0.75 cubic foot size

Quantity 1 CWS Plus Backwash Control Valve w/ Bypass Assembly and Pipe connector kit (1" or ¾")

Quantity 1 8" x 44" filter tank with distributor tube

Blue media funnel for adding the Greensand media

10lbs. Filter gravel

0.75 cubic foot of Greensand media

Greensand Filter 1.0 cubic foot size

Quantity 1 CWS Plus Backwash Control Valve w/ Bypass Assembly and Pipe connector kit (1" or ¾")

Quantity 1 10" x 44" or 9" x 48" filter tank with distributor tube

Blue media funnel for adding the Greensand media

12lbs. Filter gravel

1 cubic foot of Greensand media

Greensand Filter 1.5 cubic foot size

Quantity 1 CWS Plus Backwash Control Valve w/ Bypass Assembly and Pipe connector kit (1" or ¾")

Quantity 1 10" x 54" filter tank with distributor tube

Blue media funnel for adding the Greensand media

16lbs. Filter gravel

1.5 cubic foot of Greensand media

Greensand Filter 2.0 cubic foot size

Quantity 1 CWS Plus Backwash Control Valve w/ Bypass Assembly and Pipe connector kit (1" or ¾")

Quantity 1 12" x 52" filter tank with distributor tube

Blue media funnel for adding the Greensand media

20lbs. Filter gravel

2.0 cubic foot of Greensand media

Pre-Installation

1. Review your packing list and make sure you have received all the parts before beginning installation.
2. If you are going to be turning off the water to the house and you have an electric water heater, shut off the power to the water heater before beginning installation in case water heater is accidentally drained.
3. Pick a suitable location for your filter system on a dry level spot where it won't be exposed to freezing temperatures. A minimum of 20 PSI is required. Maximum pressure is 90 PSI.
4. Get all of your plumbing parts together before beginning installation. Installation typically takes 3 to 5 hours. However, after installation the Greensand Filter must be allowed to run through a complete backwash and rinse cycle.
5. After the system is installed and running, your water may be discolored, or full of sediment or rust, particularly if this is older or corroded piping. This typically clears up over a day or two.

Best Practices for Piping & Drain Installation

1. See typical installation on page 7 (Fig 2). The Greensand filter is installed after the pressure tank.
2. Make sure to connect the IN pipe to the CWS Plus inlet and the OUT pipe to the outlet (see Fig 2). As you face the CWS Plus control from the front, the water enters on the right and exits on the left. From the back (see Fig 2) the water enters on the left. The inlet and outlet are attached to the bypass valve, which is marked with arrows as well.
3. Make sure there is a working gate or ball valve before the CWS Plus Greensand Filter and also one after as shown in Fig 2. The pressure gauges are optional and perhaps not necessary but a hose bib (which is a faucet that you can attach a garden hose to) is strongly recommended after the Greensand Filter and before the second ball valve. This makes it easy to rinse your new Greensand Filter on start-up and gives you a place to test the water before it enters your household plumbing.

CWS Plus Greensand Filter Installation & Startup Guide

4. If you will be using copper piping, do not sweat the copper pipe directly on to the CWS Plus control valve. Avoid heating up the CWS Plus control valve plastic with the torch.
5. You do not need unions to install your CWS Plus control valve. If you need to remove it, the CWS Plus has quick-release couplings that make it easy to put the Greensand filter on by-pass and remove the filter system from the piping.
6. The drain line tubing (not supplied) is connected to a drain from the drain outlet using flexible ½" ID tubing. Note that the drain can run up above the CWS Plus control and into a drain, it does not have to drain down, as the filter backwashes under line pressure from your well pump. Most plumbing codes require an air-gap connection, so that if your sewer or septic tank backs up, it cannot cross connect with the drain tubing.

How Your Greensand Filter Works

See Fig 1. In greensand iron filter, the water enters the top of the tank and flows down through the media and up the distributor tube. Iron and manganese in the water turns to an oxidized particle upon contact with the media and is trapped in the media. During backwash, the water flow is reversed and water flows down the distributor tube and up through the media, lifting and expanding the greensand filter media, and removing all the iron and rust trapped in the filter. After the backwash stage, potassium permanganate solution is automatically drawn in from the potassium permanganate solution tank and slowly rinses through the greensand filter for 1 hour, and then the greensand media is thoroughly rinsed-to-drain. This entire automatic process, called 'regeneration' takes about 90 minutes. Typically the greensand filter is set to regenerate every 3 to 7 days, during the middle of the night when no water is being used.

Fig 1 - Greensand Filter Tank Water Flow

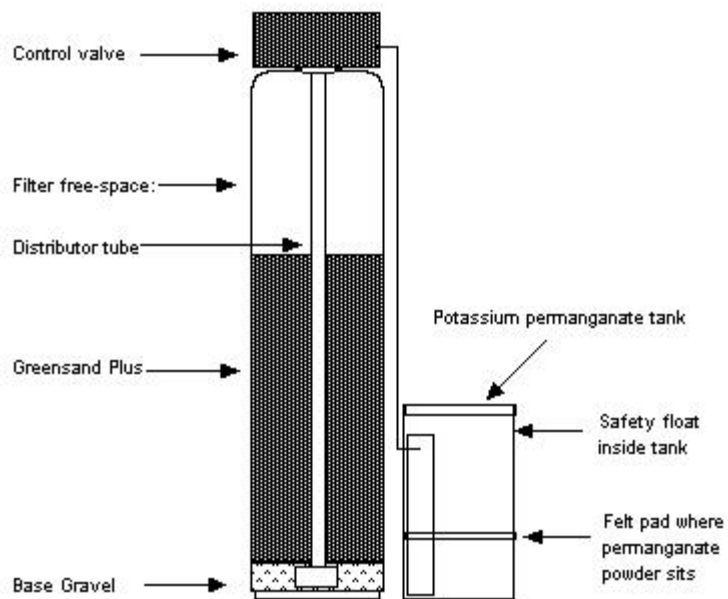
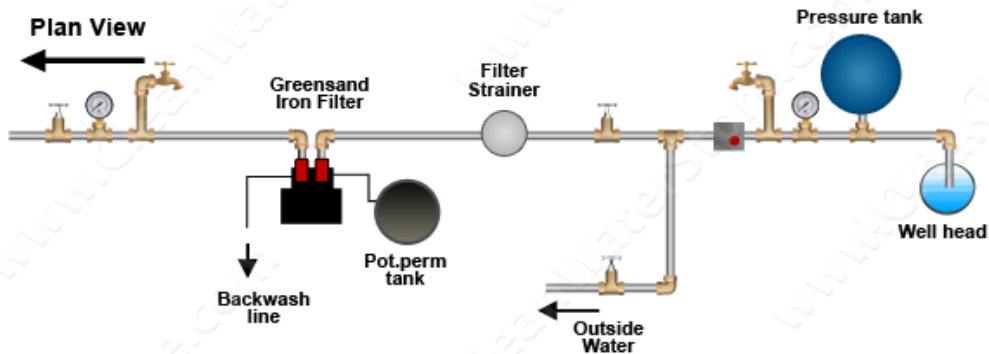
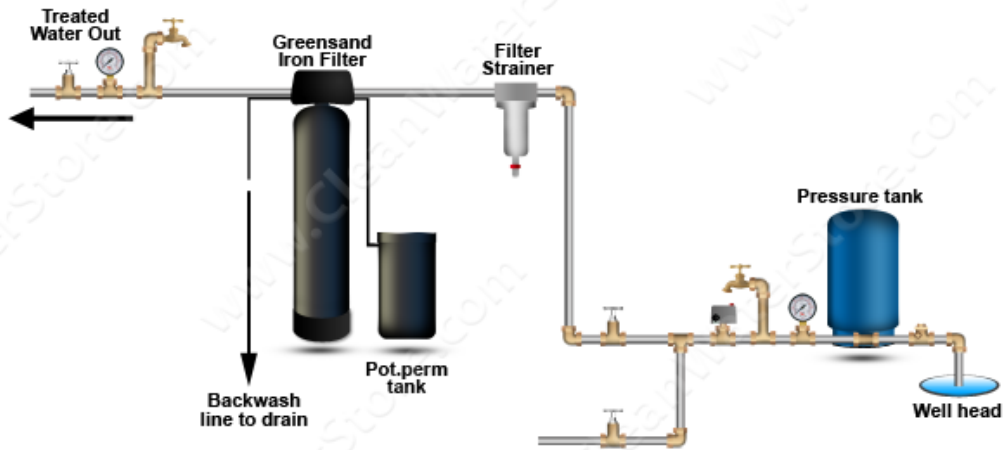

Fig 2 - Typical Greensand Filter CWS Plus piping installation with ball valve and hose bib after the filter



www.cleanwaterstore.com

- Key**
-  Water piping
 -  Check Valve
 -  Hose Bib
 -  Pressure switch
 -  Pressure Gauge
 -  Gate or ball Valve

Fig 3: CWS Plus from the rear showing the inlet (left) and outlet (right) end-connector fittings 1" or 1-1/4" NPT in Noryl plastic. Brass end-connectors are also available for connecting to copper tubing.

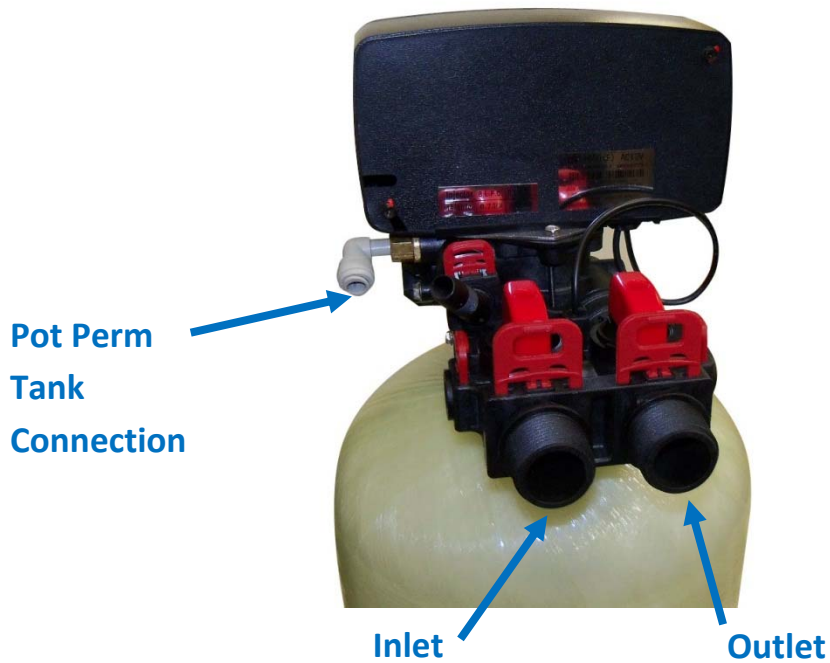
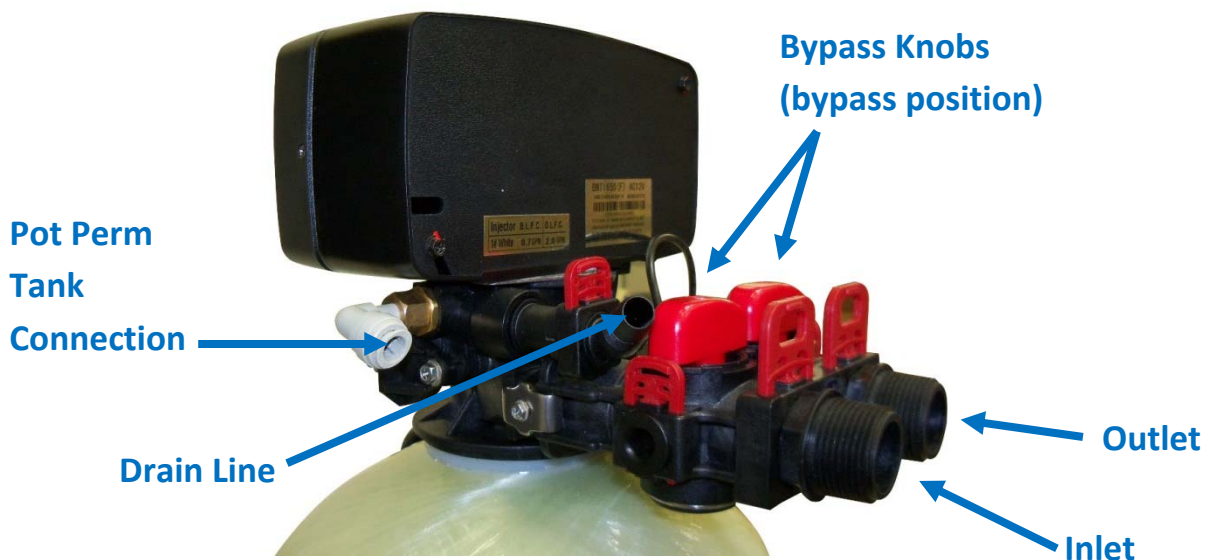

Fig 4 CWS Plus side view



CWS Plus Greensand Filter Installation & Startup Guide

Assembly and Installation Instructions

1. By hand, unscrew the entire CWS Plus control valve from top of tank if it was shipped screwed on. Place distributor tube in tank if not already inside. If not already done, make sure the blue cap is on top of distributor tube, or wrap the top of distributor tube with electrical or duct tape. You do not want gravel or Greensand to go down the distributor tube.

Plug or tape top of distributor tube when adding media to prevent media from entering. Remove when finished.

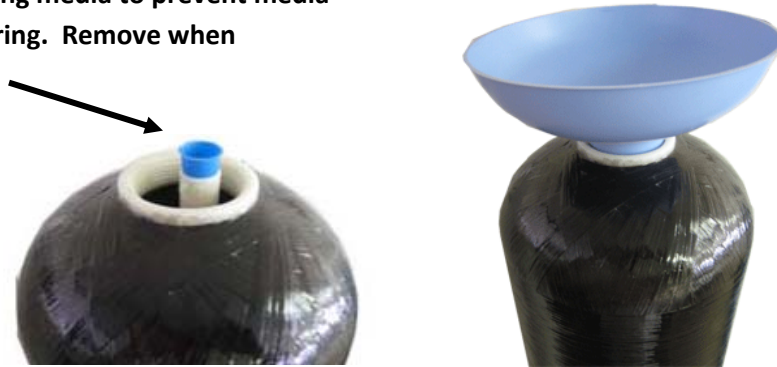

2. Add the filter gravel that came with your order. You want the gravel to cover the bottom distributor screen before adding the Greensand media.
3. Next add Greensand media. The tank should be about 2/3rds full of media.
4. Remove cap or tape from top of distributor tube. Be careful not to pull up distributor tube when removing cap or tape.
5. If possible at this point, fill tank completely with water. This will allow the Greensand Filter media to settle and eliminate the need of “purging” the air out of the tank later.
6. Attach plastic top screen to the under-side of the CWS Plus control valve. It is a funnel-shaped plastic screen that snaps on to the control valve and prevents resin from being backwashed out to drain during the regeneration cycles.



CWS Plus Greensand Filter Installation & Startup Guide

7. Add a small amount of silicone grease or vegetable cooking oil to the tank threads and screw on CWS Plus control valve carefully. Do not use pipe-joint compound, Teflon tape, or Vaseline or other petroleum greases to lubricate tank threads.
8. See how the CWS by-pass is connected. Note that Items 2 in Fig 3 below are the pipe connectors and the other end is what gets attached to the control valve. Items 3 are the red clips that hold the pipe connectors to the by-pass valve. **Your CWS Plus is usually shipped in the by-pass position, as in Figure 4.**

Fig 5 CWS Plus By-Pass and Pipe Connectors

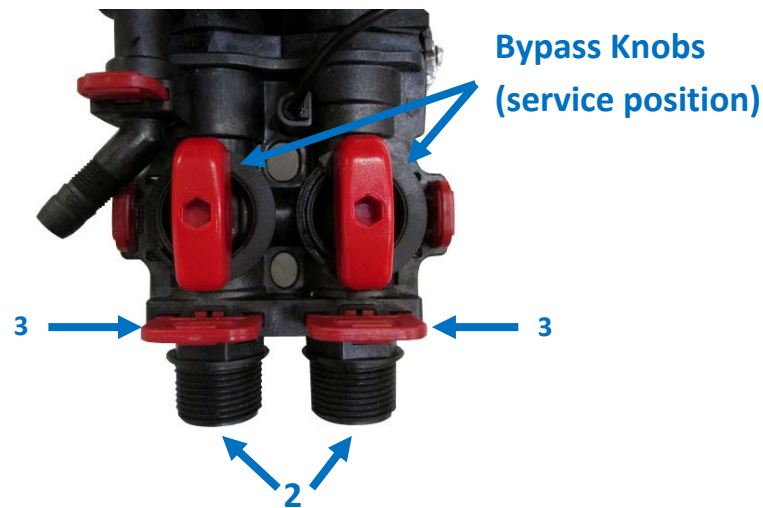

9. Lubricate the by-pass valve o-rings with some vegetable oil or silicone grease and connect the bypass assembly to the CWS Plus control by sliding the bypass valve firmly into the body of the CWS Plus. Once bypass is in far enough, you will be able to insert the red connector clips.
10. Next lubricate the end-connectors (#2 in Fig 3) with some silicone grease or vegetable cooking oil and insert them into the bypass valve and then insert the red clips (#3).
11. Note that the CWS Plus is usually shipped in the bypass position. There is a bypass valve knob on both the inlet and the outlet (Fig 3 #1). You can easily tell if it is in bypass because the two knobs will be in line with each other (Fig 4). If the valve is in the Service position (Fig 5) the knobs will be parallel to each other. Make sure both sides are in the by-pass position.
12. Do NOT remove the red clips in order to put the bypass valve in either bypass or service, it is not necessary nor desired to remove the red clips on the bypass valve hand knobs (see Fig 3 item 1, which are the knobs you will turn to move the bypass valves).
13. Now install your water pipes to the CWS Plus bypass end connectors. Make sure inlet is installed to the 'In' pipe connector on the bypass valve and outlet is on the "Out" connector.

CWS Plus Greensand Filter Installation & Startup Guide

14. Connect some flexible tubing from the drain connection on the CWS Plus control valve to a suitable drain such as a septic tank or drain to a sewer. It is OK to run the drain line up and over the CWS Plus Greensand Filter up to 4 feet above the top of the tank. If the drain line will be more than 20 feet, use larger diameter tubing such as $\frac{3}{4}$ " or 1". Note that it is desirable to be able to run the drain line into a bucket in order to test the backwash flow rate in the future. This is why hard piping the drain line is discouraged, however, if you do use hard PVC piping for the drain line, and you are able to remove the hard PVC drain piping and attach flexible tubing should you ever desire for testing purposes, it is OK to use rigid PVC pipe for the drain. Make sure the drain tubing is firmly clamped to the barbed fitting with a hose clamp to prevent leaks.



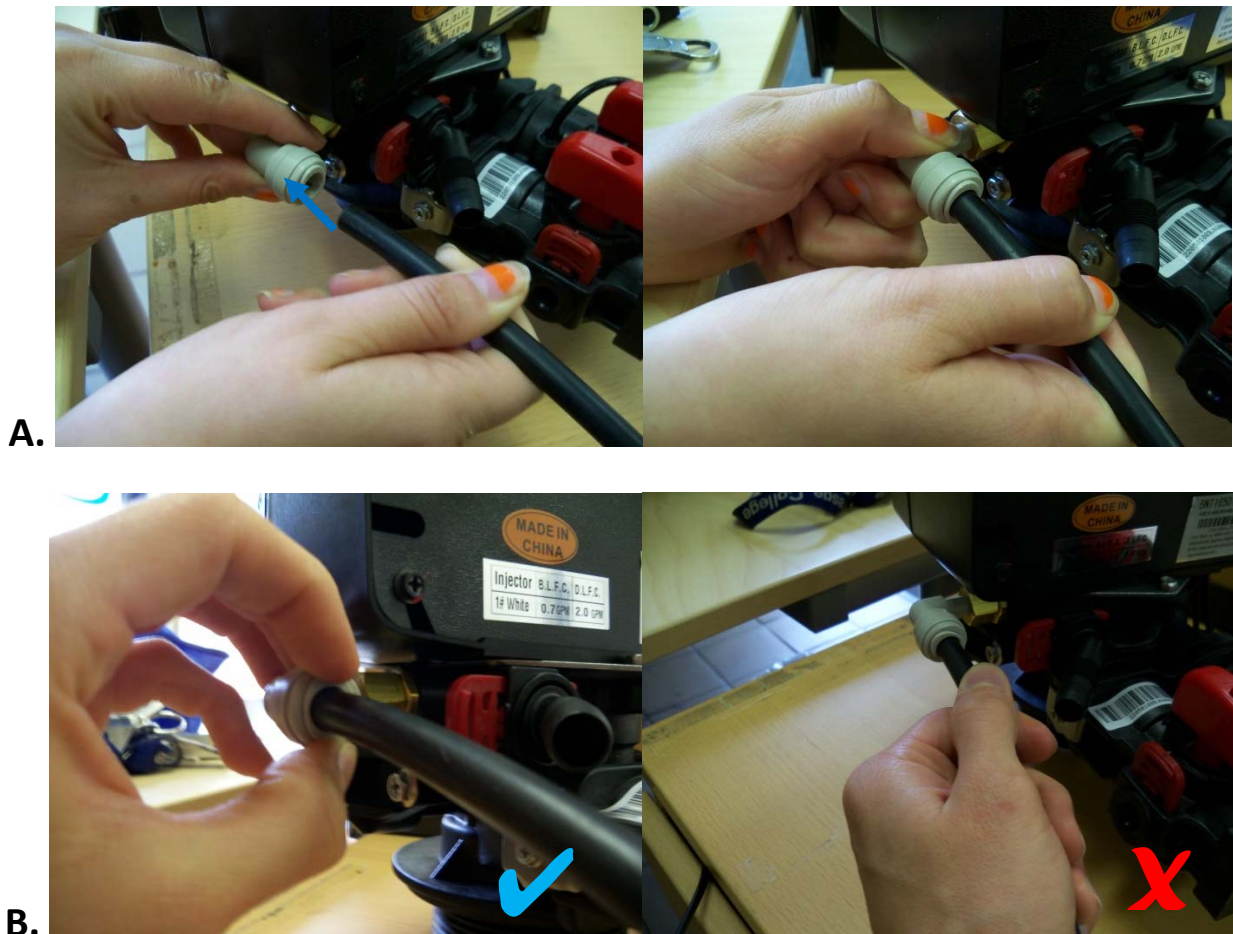

Fig 6 CWS Plus Pot Perm Line Installation



15. Insert $\frac{3}{8}$ " diameter tubing into the potassium permanganate tank connection. Simply push the tubing into the fitting until it can go no further; the tube should be snug in the fitting (Fig 6A). If you need to remove the tubing, hold the flanged ends of the tube insert against the fitting and firmly pull the tubing out (Fig 6B); simply pulling on the tubing can damage the fitting.

Fig 7 CWS Plus Pot Perm Tank Set-Up & Installation



16. First remove the rubber band that comes on the float assembly from the manufacturer. Add enough clean water to the pot perm solution tank to bring water level about 1" above the felt pad. Add one 2 or 5-lb jug of potassium permanganate granules to the potassium perm tank by pouring it directly on top of the white felt pad. Do not pour permanganate down the white plastic brine well where the black line is attached.
17. See the over-flow barbed fitting on the side of the perm tank. You do not have to connect this to a drain. If the safety float were to malfunction, there is a small chance that pot perm solution will drip out of this fitting. If this would cause a big mess where you have installed the greensand filter, hook some tubing to this and run to a bucket, floor pan or floor drain. Normally no pot perm solution will leak out of this fitting.
18. Plug your CWS Plus control valve into an outlet. After being plugged in, the screen may display "WAITING PLEASE" while it finds the service position. Next you will need to program the system to work as a Greensand Filter. There are a few settings that must be changed before the system can be put into service.
19. PROGRAMMING:
 - a. First, press the menu button labeled  once. If it says "SCREEN LOCKED," you may have to press and hold the upper left button labeled  about 3 seconds until a beep sounds to unlock the display screen.
 - b. NOTE: Use the up and down arrows to cycle through the various program settings. To change any setting, press '  '. When the display flashes, the value may be changed. Press either the up or down arrow to change the value. Press '  ' once more to accept the value, and the display should stop flashing to indicate that the setting has been saved.
 - c. Step 1: REGIONAL US GAL (this stands for US gallons format, if it is different, change it to US GAL). When it is set, press the down button to proceed to the next step.

CWS Plus Greensand Filter Installation & Startup Guide

- d. Step 2: The display should be set to: "CALENDAR CLOCK". By default, the system is most likely set to "METER IMMEDIATE" or "METER DELAYED." We recommend CALENDAR CLOCK for the operation of your Greensand Filter, to backwash a set number of days. Change the setting, then press the down arrow to proceed to the next step.
 - e. Step 3: TIME- set the time of day. Press the down button to proceed.
 - f. Step 4: REG. TIME - Set to 2:00 AM generally or sometime when no water is being used, and no other filter or softener is likely to be in a regeneration cycle. Then press the down button.
 - g. Step 5: REG. DAYS - This tells the greensand filter how often to regenerate in days. It can be set for any setting from 1 to 7, with 4 being the recommended common setting. If you are having some problems with iron bleed-through after the filter has been online for a few days, you may want to change it to 2 or 3 days.
 - h. Step 6: BACKWASH - Stands for BackWash length in minutes. It should be set to 10 MIN which means 10 minutes of backwash. If your water is extremely high in iron you can change this setting to 12 or 14 minutes to allow some extra backwash time, but 10 minutes is a good setting. Press the down button one time.
 - i. Step 7: BRINE - stands for Brine Draw. This is the cycle where solution is sucked in from the potassium permanganate solution tank. This cycle is 60 minutes long and should display: 60 MIN. Press the down button one time.
 - j. Step 8: RINSE - This is the Rapid Rinse cycle and should display: 10 MIN. Press the down button one more time.
 - k. Step 9: REFILL - This is the Brine Fill, where the potassium permanganate is refilled with water to make solution for the next cycle. This should display: 2.9 MIN. This means it the cycle will last for 2 minutes and 54 seconds. This final cycle adds water to the POT PERM solution tank. That is fine for this application. Press the down button one time.
 - l. Programming is finished- to exit, press the upper menu button  one more time to return to Service mode.
20. Now you can start the initial manual backwash. Turn the manual knob clockwise to "BA. WA" and a manual backwash will begin.
21. Very slowly turn the inlet knob on the bypass valve towards the service position, but DO NOT open the valve all the way. We want to allow all of the air in the tank to escape before allowing the water to flow freely. If the bypass valves are too stiff to turn by hand, insert the L shaped wrench into the handles to turn them freely.

CWS Plus Greensand Filter Installation & Startup Guide

22. Once water begins to flow from the drain line open the inlet valve all the way. Continue to let the water run from the drain line for about five minutes or until any media fines in the water are no longer present.
23. If possible verify that the backwash flow is 5 gallons per minute, which is the recommended backwash flow rate for 1.0 and 1.5 cubic foot models. You can easily run the drain hose to a bucket and using a watch verify the flow rate in gallons per minute. An adequate backwash is critical to properly clean the Greensand media and prevent it from cementing together.
24. Once the water is clear, press any button to advance to the “Rinse” position. Once again, allow the water to flow for about five minutes or until the water is clear.
25. Press any button to advance to the “Service” position. Next, open the outlet on the bypass valve and then open the nearest treated water faucet to the unit and allow the water to run until it is clear. We advise using a bathtub, laundry sink, or other fixture that does not have an aerator screen as any remaining residue may get caught in the screen.
26. Refer to your CWS Plus service manual for more information about how your control valve is programmed if desired.

Maintaining Your Greensand 2510 Filter System

Adding Potassium Permanganate:

Add one 5-lb jug of potassium permanganate every 3 - 4 months. Check the potassium permanganate solution tank and when you see the mound of potassium permanganate disappear after a few months, just add another 5-lb jug. In some cases, you won't see the mound; you might just see solution after a couple of weeks. This is OK; you still only need to add the potassium permanganate every 3 months in most cases. If you have it set to regenerate (backwash cycles) every 1 – 3 days, you might need to add it more frequently, perhaps every 2 months.

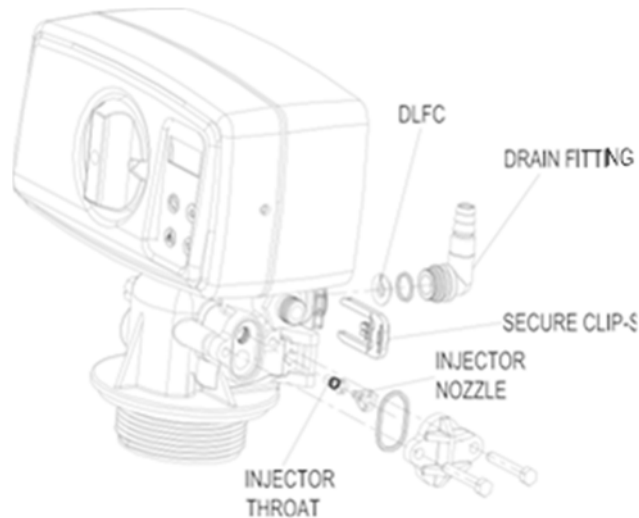

Clean the Injector

Once a year, clean the permanganate solution tank and the brine injector.

1. Shut off water to filter or put filter on bypass.
2. Release water pressure by turning the center knob on the timer assembly by a few degrees clockwise.
3. Unplug the control valve from the electrical outlet.
4. Unscrew the bolts near the brine line fitting using a small screw driver. Using this small screwdriver, remove the injector nozzle and throat, unscrewing counter-clockwise. You may need to use a paper clip or other piece of wire to remove the lower nozzle once it is unscrewed.
5. Replace and/or clean parts the throat and nozzle in muriatic acid or vinegar.
6. Put the system back in service and plug in the control valve. Make sure the timer assembly is advanced so the piston is in the service position. If you are not sure, wait two hours until the timer assembly does this automatically.
7. Next clean the potassium perm tank by removing the felt pad and cleaning in muriatic acid, citric acid or vinegar, or better yet just replacing the felt pad if you want. Clean the float and rinse the pot perm tank out. It's better to use rubber gloves when you are doing this to avoid the possibility of staining your hands with potassium permanganate. If your hands do become stained you can clean them with vinegar or lemon juice.

Troubleshooting the CWS Plus Greensand Filter

PROBLEM / SYMPTOM	POSSIBLE CAUSE	SOLUTION
Iron or manganese or sulfur odor in treated water after Greensand Filter	No permanganate in solution tank	Add permanganate powder to tank and regenerate greensand filter
	Not backwashing often enough	Set to backwash more frequently. Backwash twice in one day and re-check water.
	Water being used when Greensand Filter is in regeneration.	If any water is used during the 90 minute regeneration cycle, untreated water will enter household piping. Set time Greensand Filter regenerates to a time when no one will be using the water.
	Permanganate solution is not being sucked in during the regeneration brine cycle.	Clean brine injector Clean potassium permanganate tank Replace permanganate support pad in permanganate tank Inadequate backwash flow. Make sure there that Greensand Filter is backwashing at the correct backwash flow rate (5 to 10 gallons per minute depending on size of filter). Low water pressure. Increase water pressure to unit by adjusting well pump pressure switch, or replacing well pump.
	Greensand media exhausted	Replace Greensand media with new Greensand.

CWS Plus Greensand Filter Installation & Startup Guide

Strong sulfur odor before and after Greensand filter	High levels of hydrogen sulfide gas in well water	In some cases, the greensand filter may need a chlorine feed (or ozone, oxygen or other oxidizer) prior to the filter. Make sure Greensand filter is working correctly, and try regenerating it once or twice a day for one week. If odor persists, replace Greensand media or add a chlorinator ahead of the Greensand Filter.
Pink water (permanganate) in household water	Inadequate backwash of Greensand Filter Clogged brine injector Inadequate rinse time Too much permanganate	Make sure Greensand Filter has adequate backwash at a good pressure and flow rate Clean or replace injector Set rinse cycle to longer time Lower float so that level of permanganate is lower in permanganate solution tank.
Potassium permanganate tank over-filling or over-flowing	Clogged brine injector	Clean or replace injector

More Troubleshooting Tips

Potassium Permanganate Not Being Sucked In During Regeneration

Most problems occur when the CWS Plus is not drawing in the potassium permanganate. Make sure the injector is drawing in the potassium permanganate:

1. Remove the permanganate solution tank tubing where it enters the CWS Plus control valve.
2. Turn the regeneration knob clockwise on the timer assembly until a backwash is started. After it is in a backwash cycle, turn the regeneration knob some more, and it will advance to the next cycle, which is the Brine Cycle, where it is supposed to suck in the permanganate solution.
3. If is sucking strongly, check the potassium permanganate solution tank float inside the brine well and make sure there is no rubber bands around it, and that is free of obstructions. In some cases it may need to be replaced or cleaned, if there is suction at the control valve, but no permanganate is being drawn in.
4. If there is NO suction at the control valve port where you removed the permanganate tubing, then the injector should be cleaned.

CWS Plus Greensand Filter Installation & Startup Guide

5. If the injector has been cleaned and there is still no suction check to make sure there is obstruction in the backwash line; that the backwash line does not go up and over the greensand filter more than several feet (which causes pressure loss and the injector not to work correctly); finally check to make sure there is enough pressure. If possible increase your water pressure to the iron filter from your well pump and see if a slightly increased pressure makes the injector work. We recommend a minimum 30 PSI but it does work better if there is 40 to 50 minimum PSI.

System Not Backwashing Adequately

The other second main problem that may occur is if you do not have enough backwash flow rate to properly clean the greensand filter. You can verify the backwash flow rate by running the drain line into a bucket and timing it when the CWS Plus is in Cycle 1 or backwash. A 1.0 or 1.5 cubic foot system should have 5 gallons per minute and a 2.5 cubic foot system should have 10 gallons per minute of backwash.

Potassium Permanganate Tank with Float

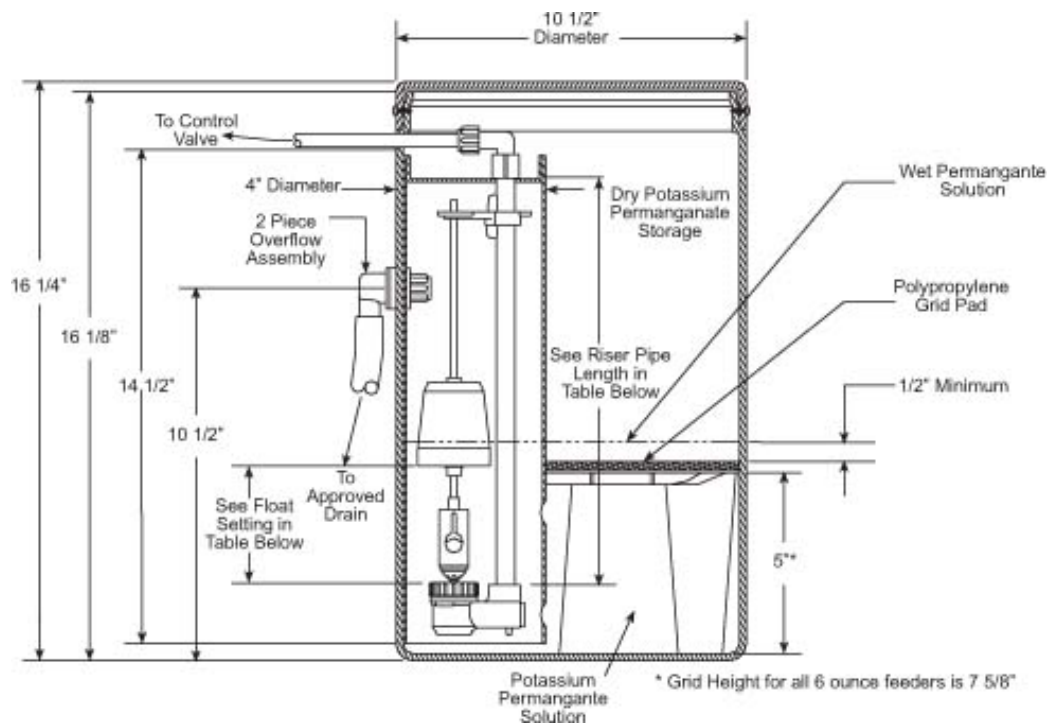

CWS Plus Greensand Filter Installation & Startup Guide

Permanganate tank not filling with permanganate solution

Potassium permanganate is a powder that is poured on top of the “grid pad” in the pot perm tank. During the brine fill cycle, water is added to the pot perm tank to make up the pot perm solution required for the next regeneration.

If your pot perm does not have ½” to 1” of solution above the grid pad, the first to check is to make sure it is filling the tank:

1. Disconnect the 3/8” black poly line at the pot perm tank or at the control valve.
2. Put the system into a regeneration cycle by turning the regeneration knob clockwise. You can advance to the Brine Fill cycle by turning the regeneration cycle further. Advance to the BF cycle.
3. If it IS filling, remove the safety float and make sure the air check ball is moving free and not stuck. A stuck float is often the cause of this problem and can be easily fixed. If the float is defective or older than 5 years, replace float.
4. If it is NOT filling during the Brine Fill (BF) cycle, then make sure there are enough minutes. It should be set for 12 minutes for standard size Clack pot perm tanks. If you have a larger commercial size tank, set for 20 minutes.
5. If it is still not filling, the brine valve may need to be cleaned. In the CWS Plus manual, in the diagram “Valve Assembly”, disconnect the parts listed and clean them thoroughly.

